

ELEMENT BAS DE CUISINE 80

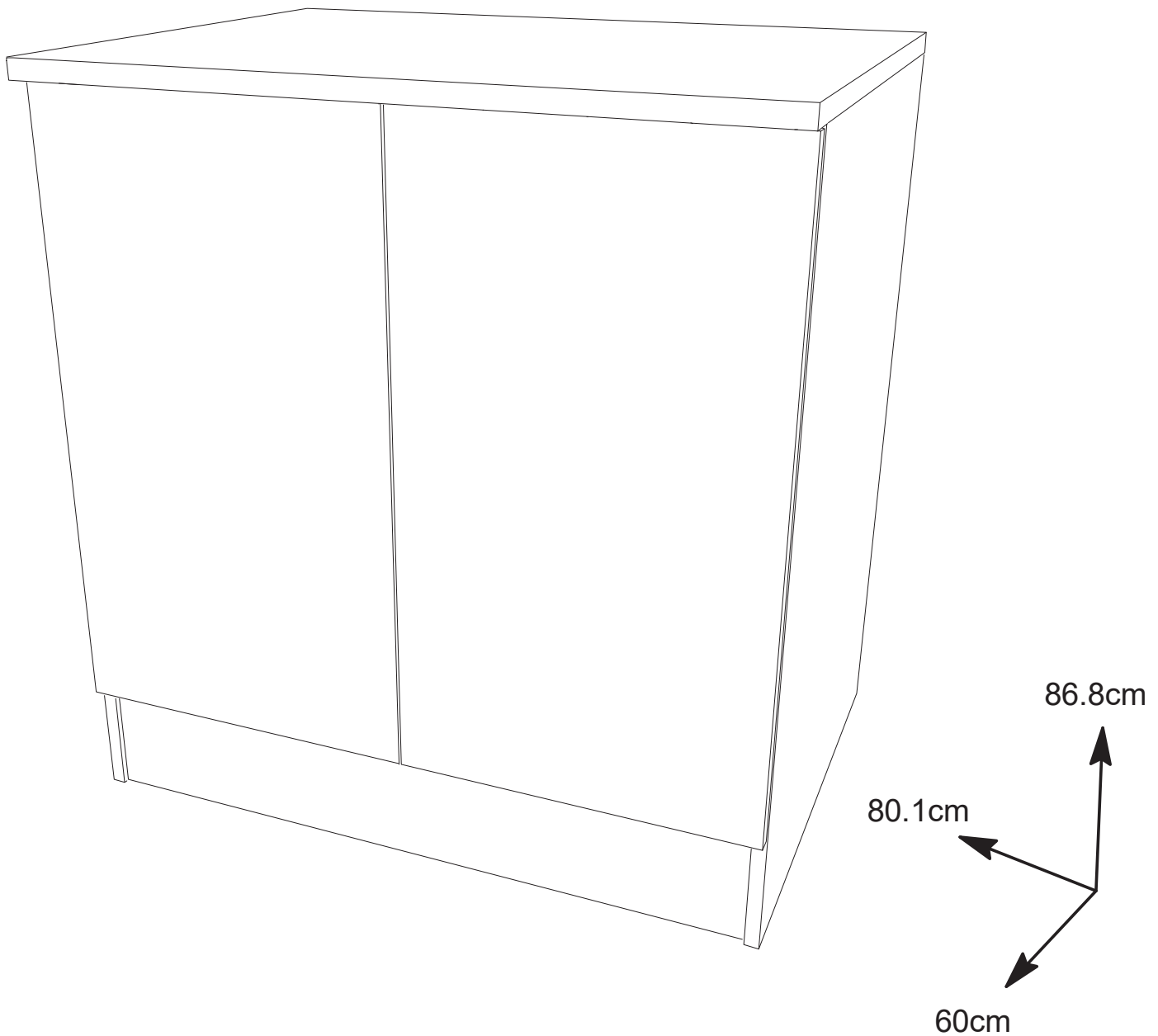

FR Remerciements :
Nous vous remercions d'avoir choisi un meuble créé et fabriqué par Ekipa et espérons qu'il vous donnera entière satisfaction.

EN Thanks :
Thank you for choosing furniture designed and manufactured by Ekipa. We hope you are totally satisfied your purchase.

ES Agradecimientos :
Les damos las gracias por haber elegido un mueble diseñado y fabricado por el Ekipa y esperamos que sea de su total agrado.

DE Danksagung:
Wir danken Ihnen für den Kauf eines Frankreich von der Ekipa entworfenen und hergestellten Möbelstücks und hoffen, dass Sie es zu Ihrer vollkommenen Zufriedenheit finden werden.



Temps de montage : 1h30

contact@parisot.com

Conseils de préparation au montage :15 min



<https://qrco.de/bcJeNz>

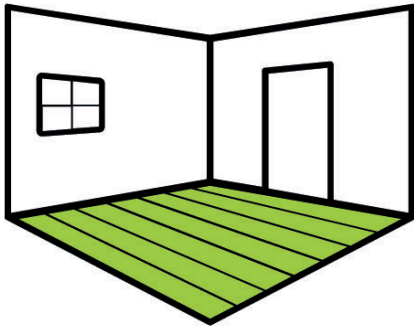

Faire un peu de place

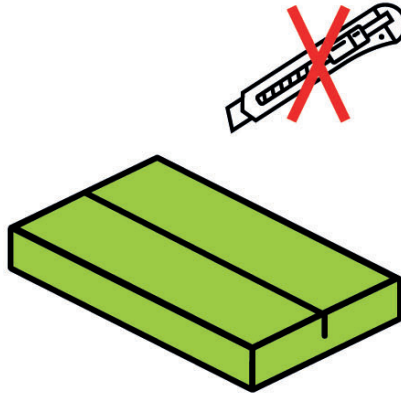

Pas d'outils tranchants

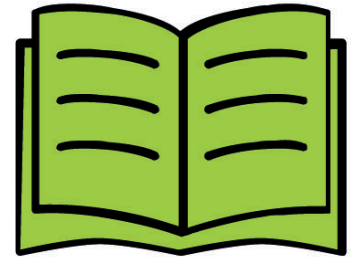

Bien suivre les instructions de la notice de montage

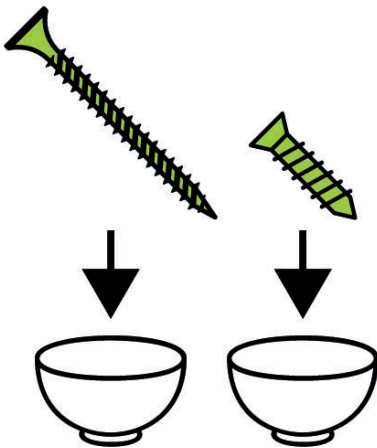

Trier vos quincailleries

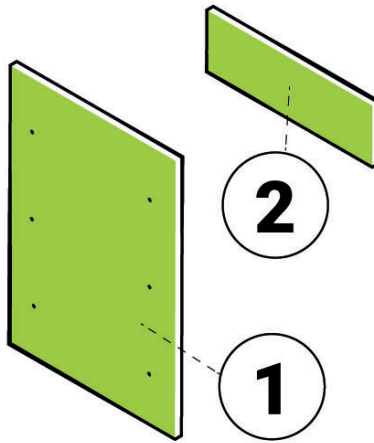

Repérer vos pièces

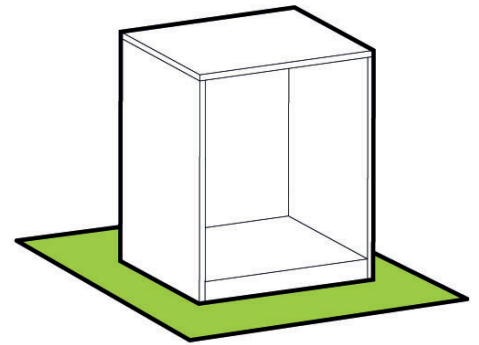

Protéger votre sol

Matériel nécessaire

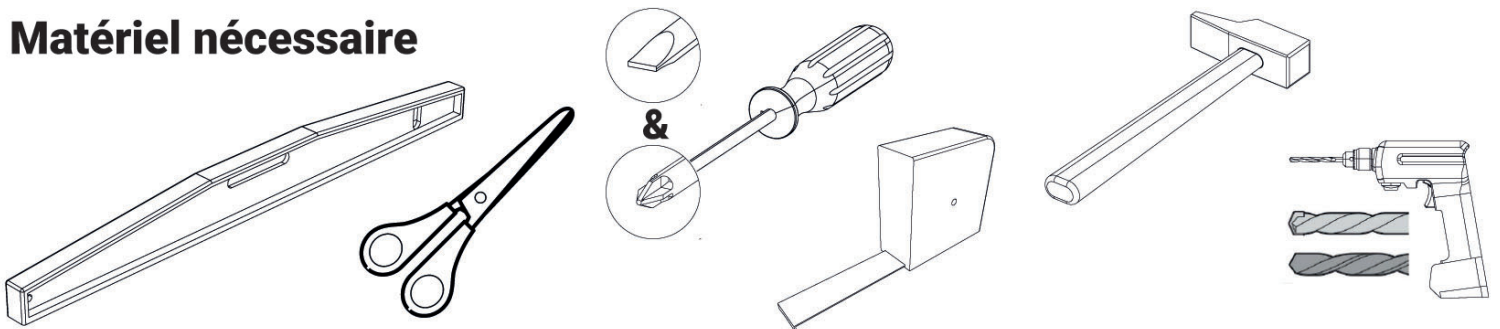

Conseils d'entretien ✓

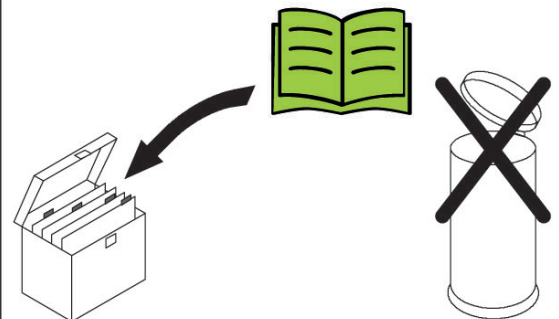

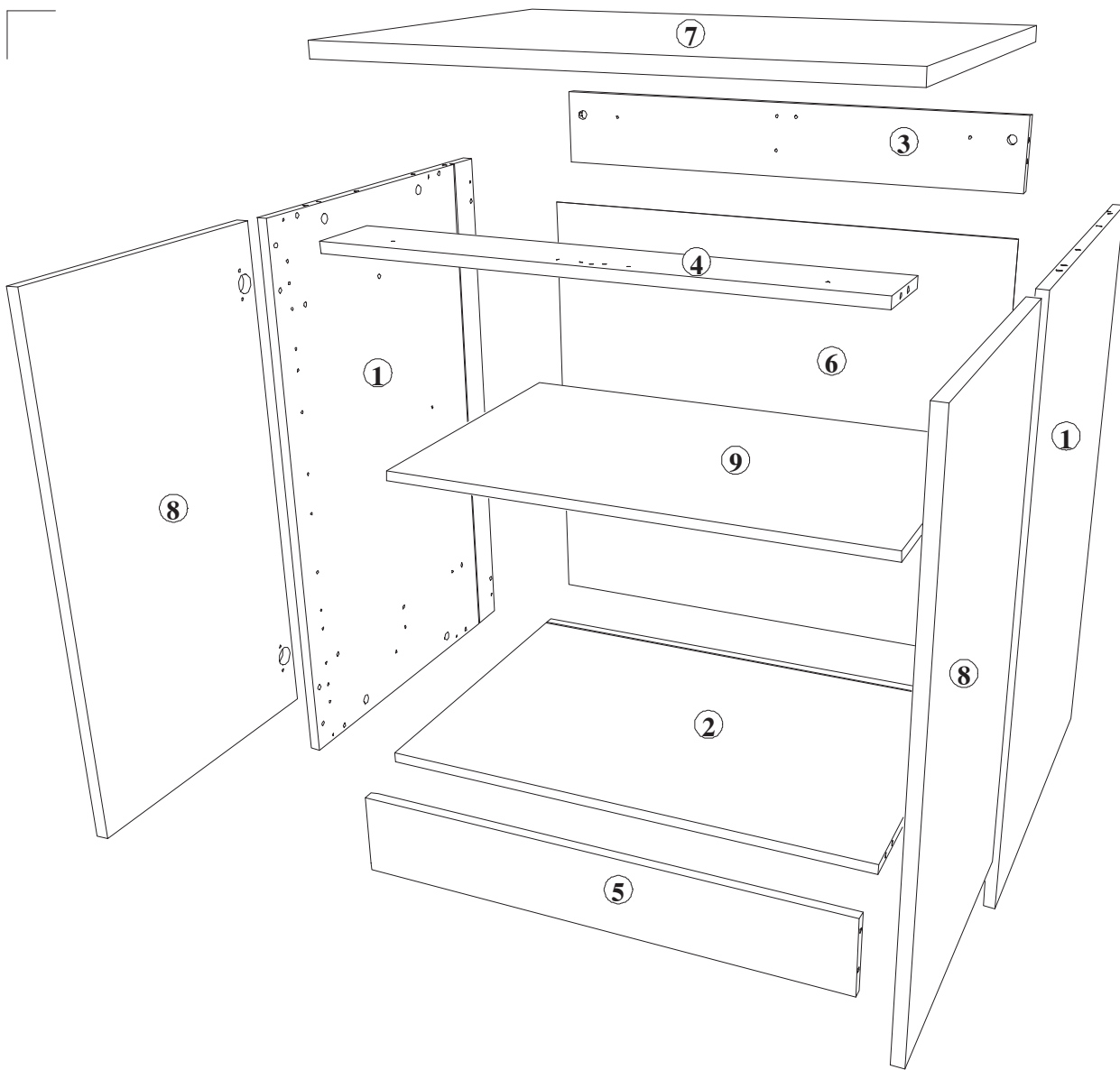

Rep	Qté	mm			inch		
01	2	838	560	16	32 63/64	22 3/64	5/8
02	1	768	519,5	16	30 15/64	20 29/64	5/8
03	1	768	115,5	16	30 15/64	4 35/64	5/8
04	1	768	110	16	30 15/64	4 21/64	5/8
05	1	768	128	16	30 15/64	5 3/64	5/8
06	1	705	780	2,5	27 3/4	30 45/64	3/32
07	1	801	600	22	31 17/32	23 5/8	55/64
08	2	702	397	16	27 41/64	15 5/8	5/8
09	1	767	472,5	16	30 13/64	18 39/64	5/8

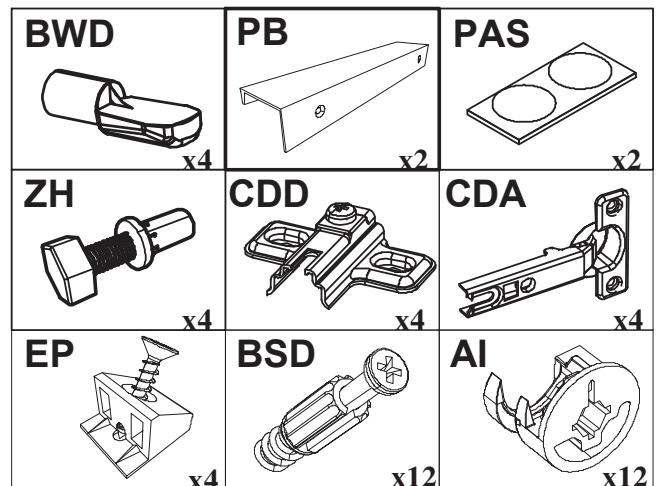
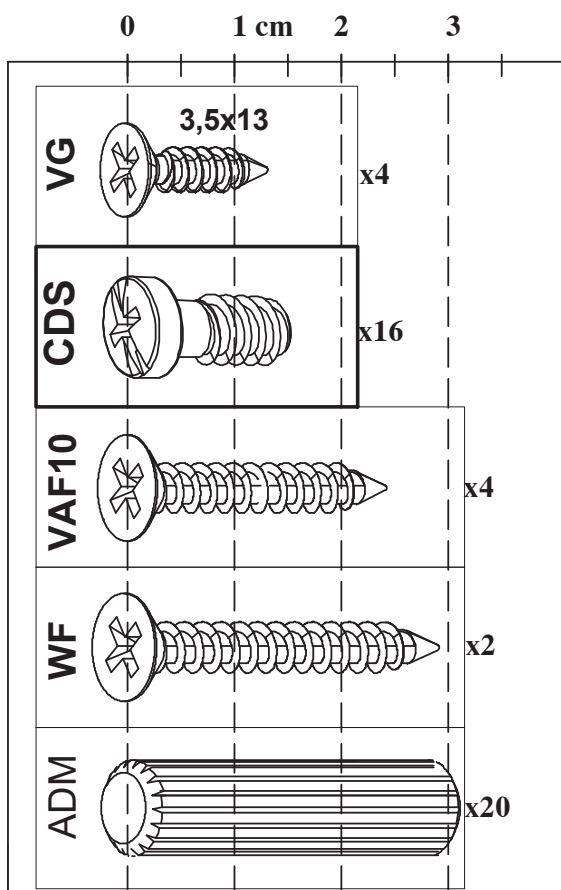

1

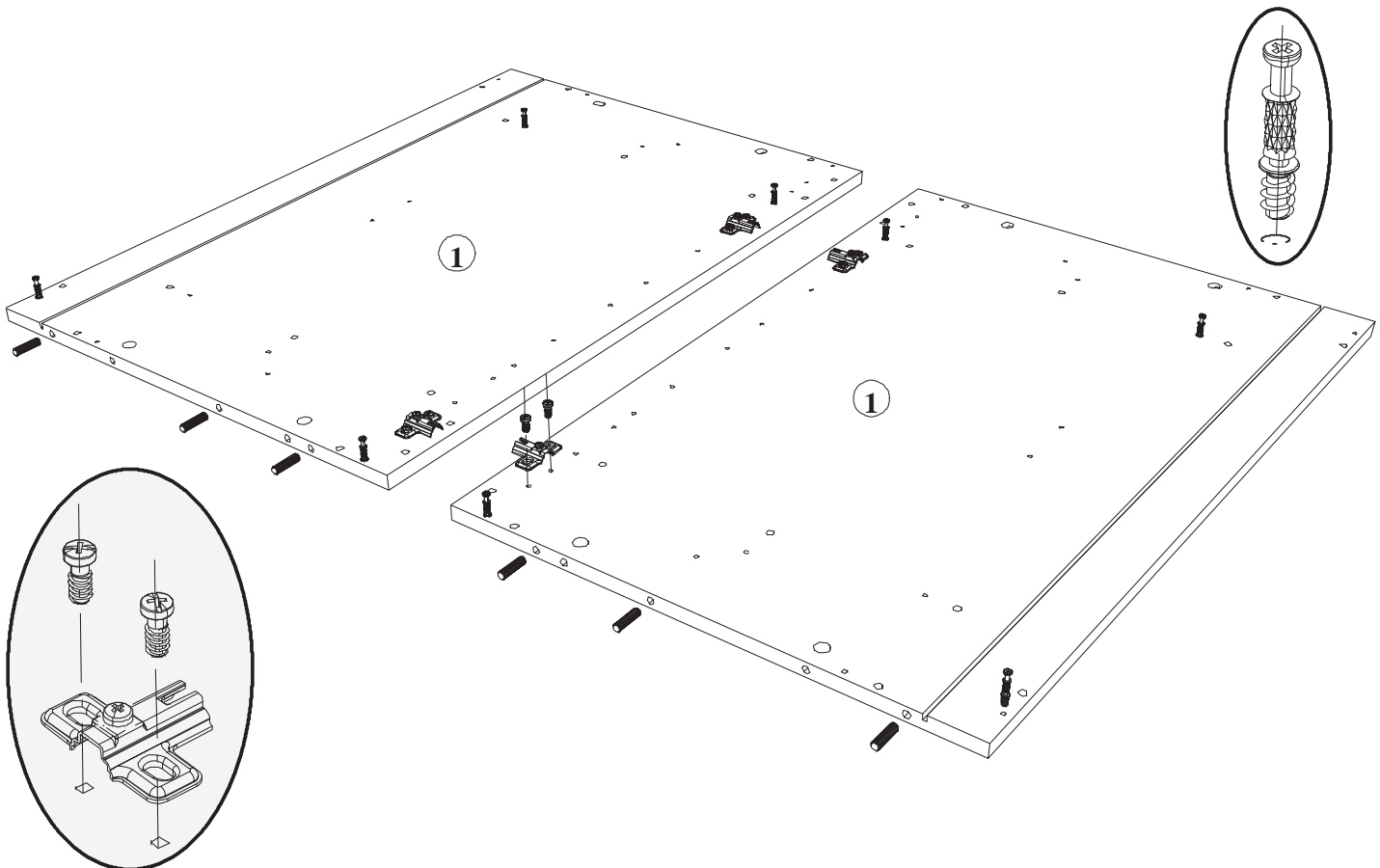
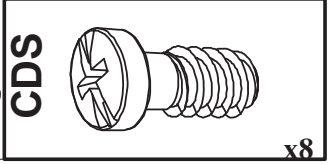
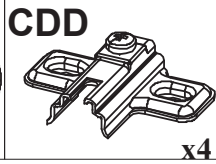
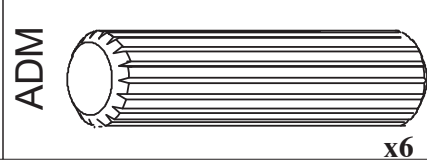
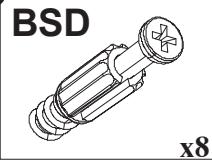

2

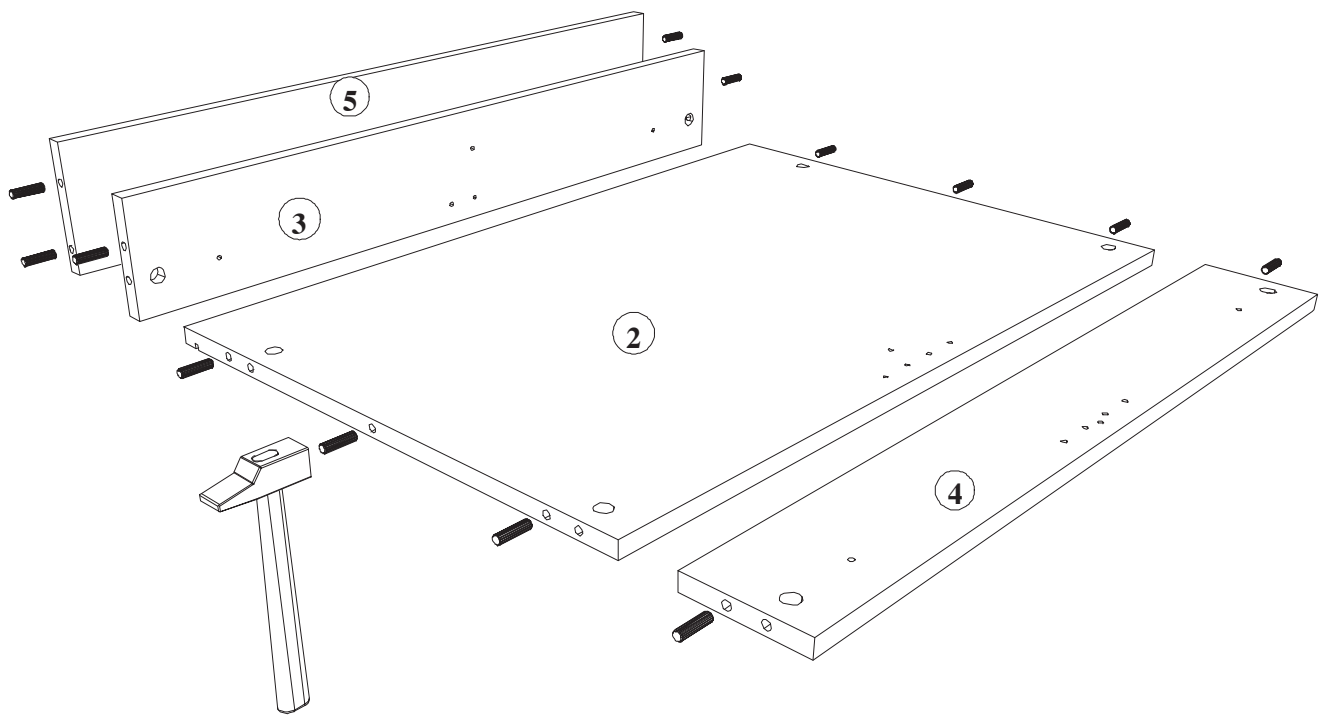
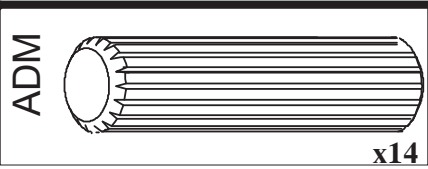

3

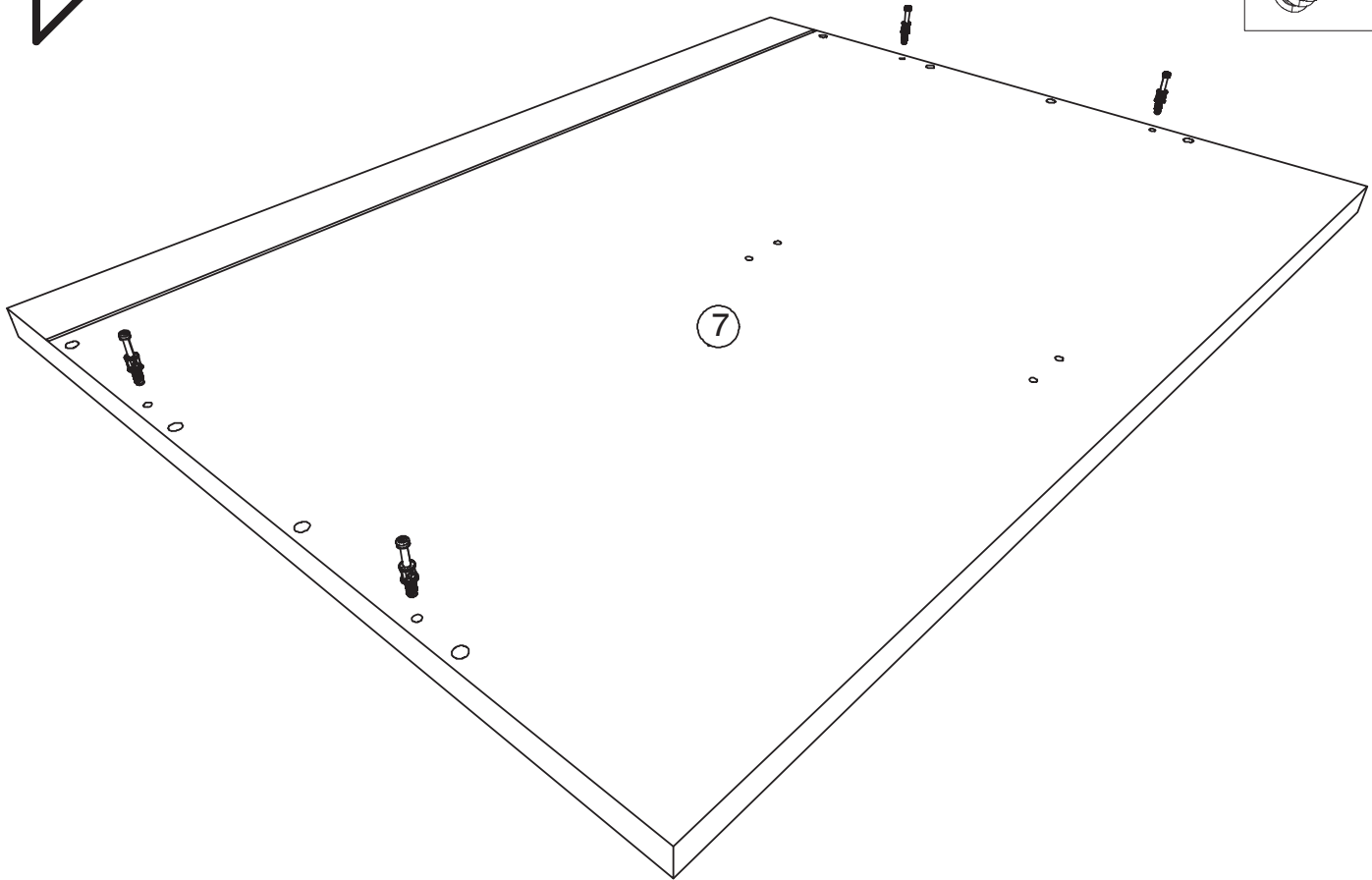
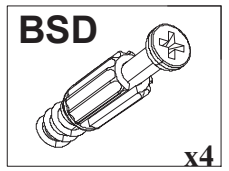

4

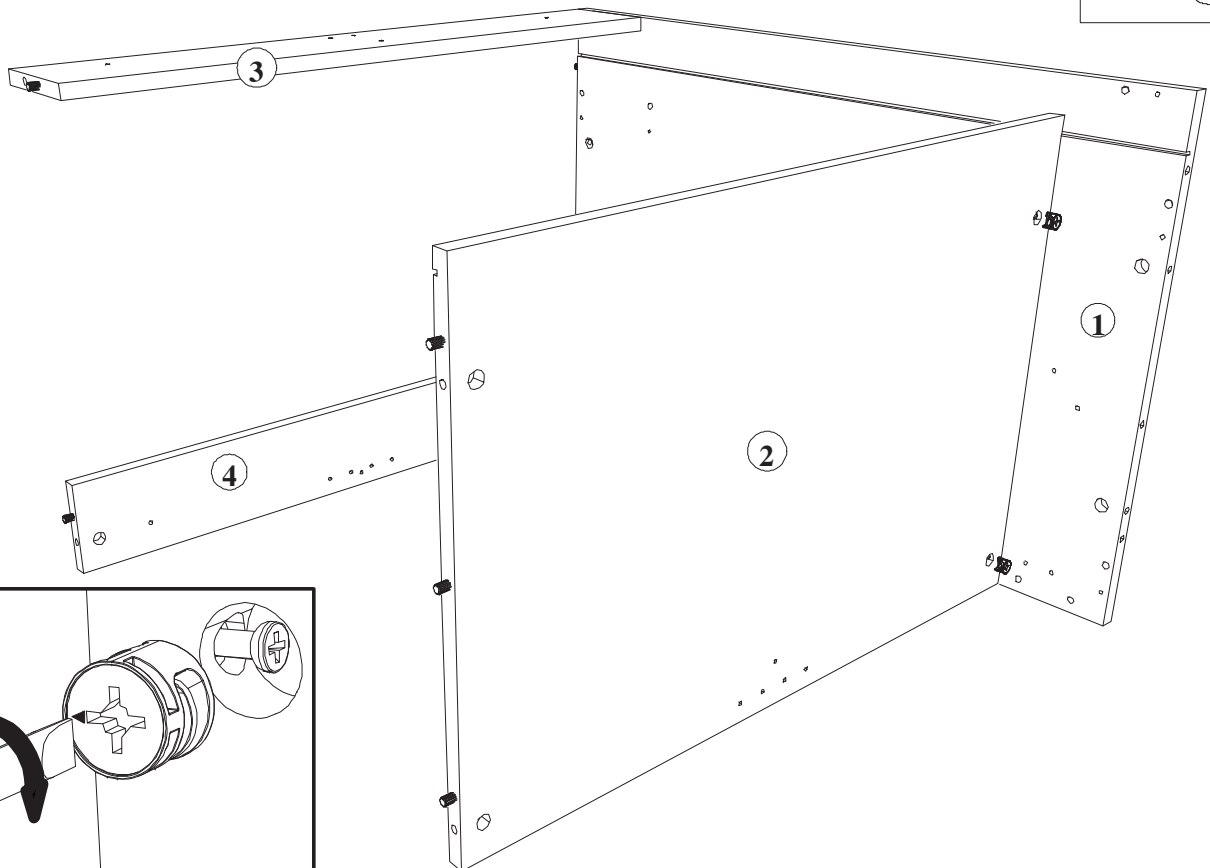
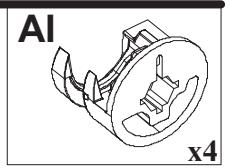

5

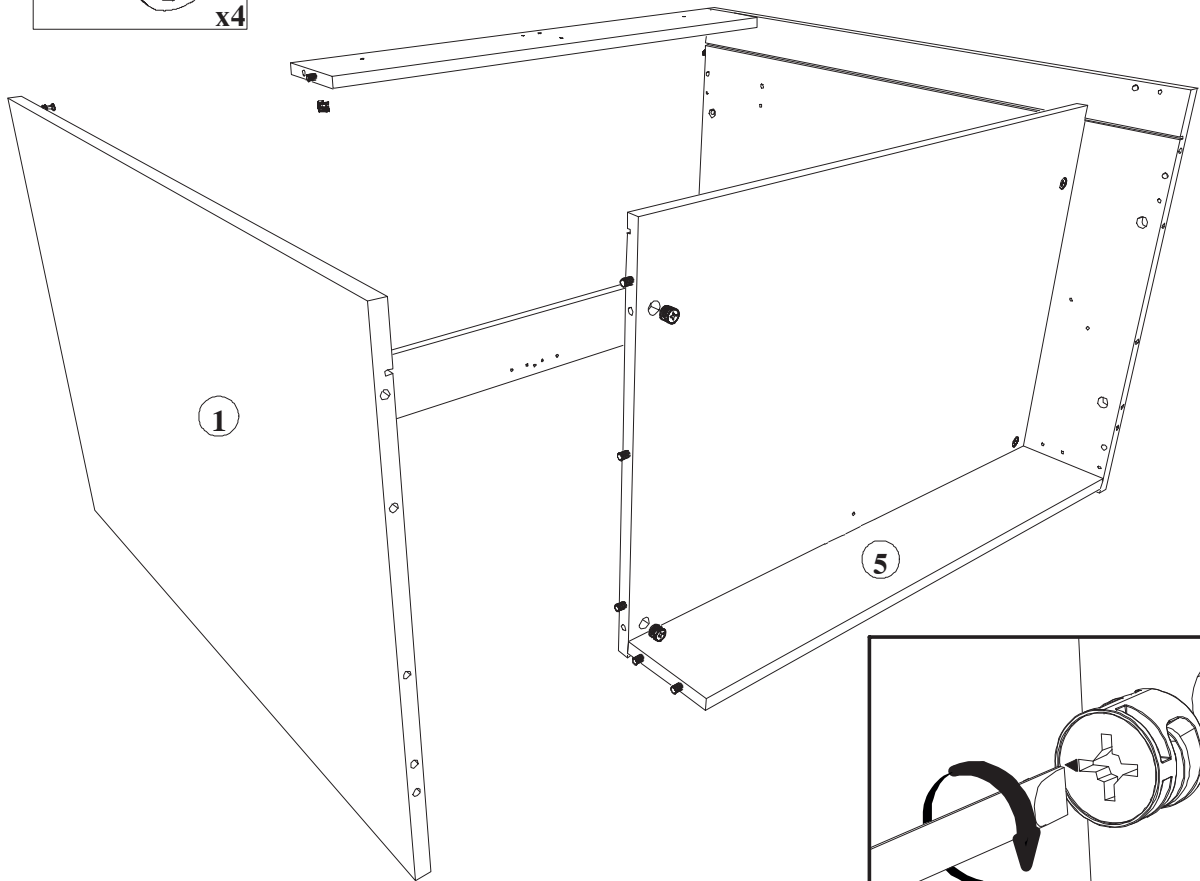
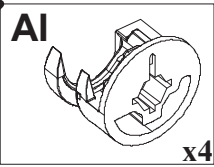

6

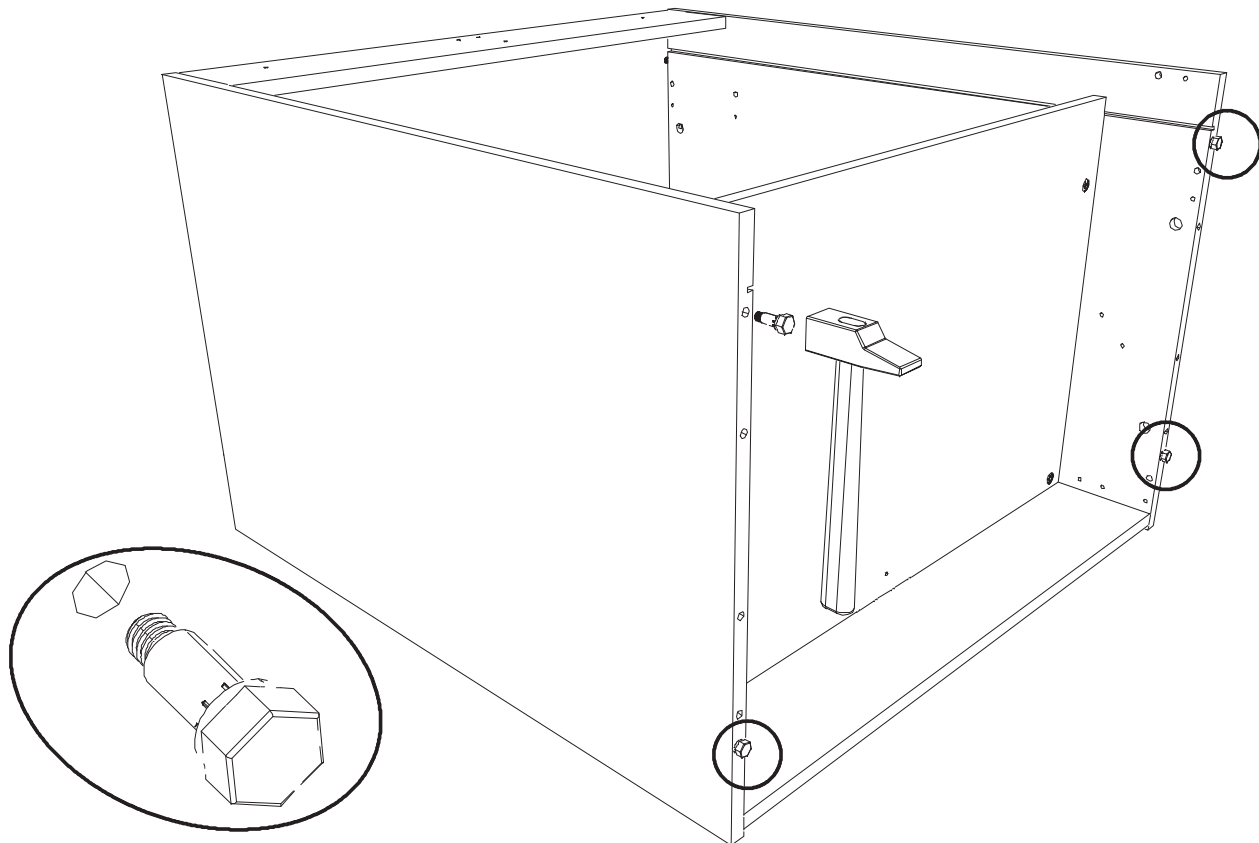
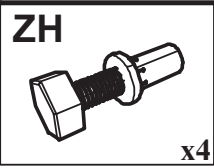

7

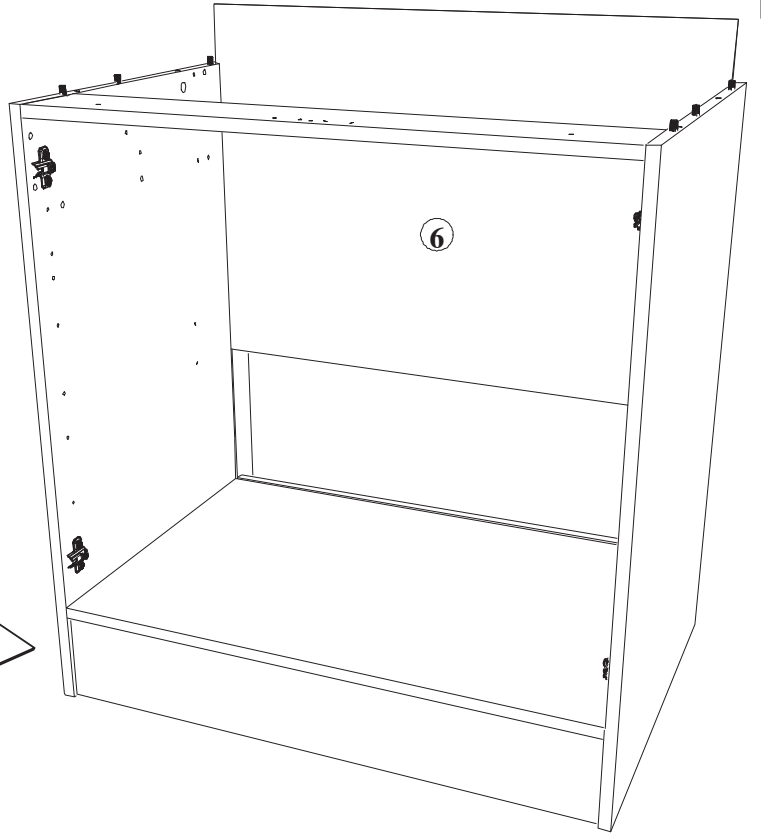
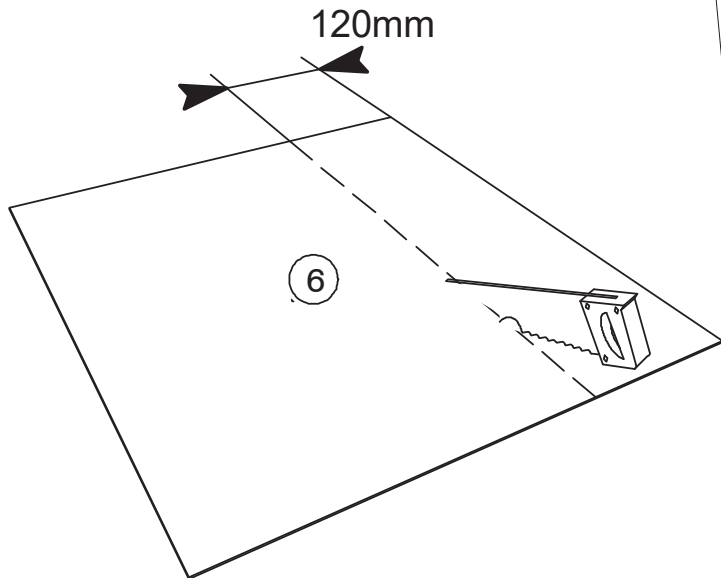

8

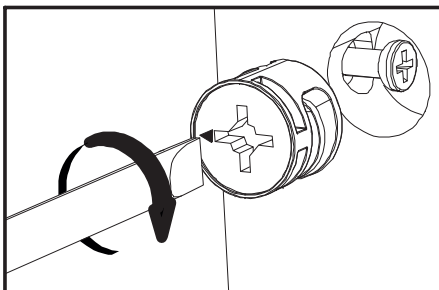
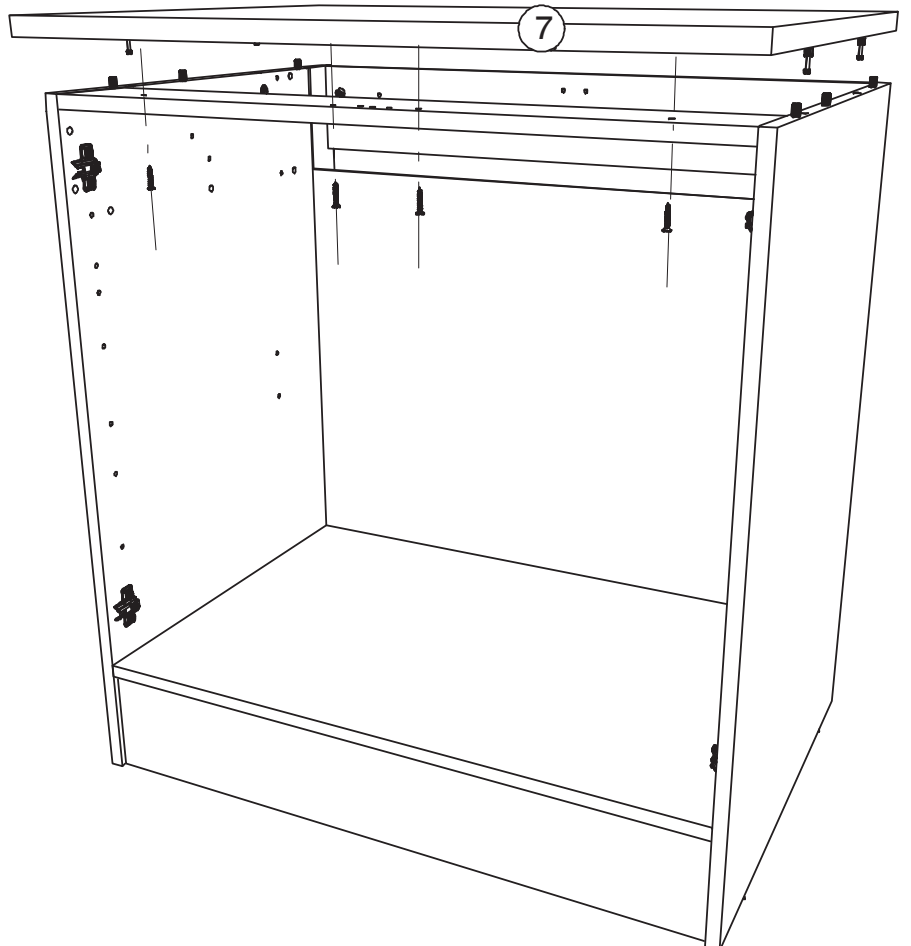
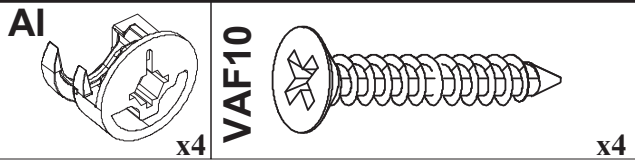

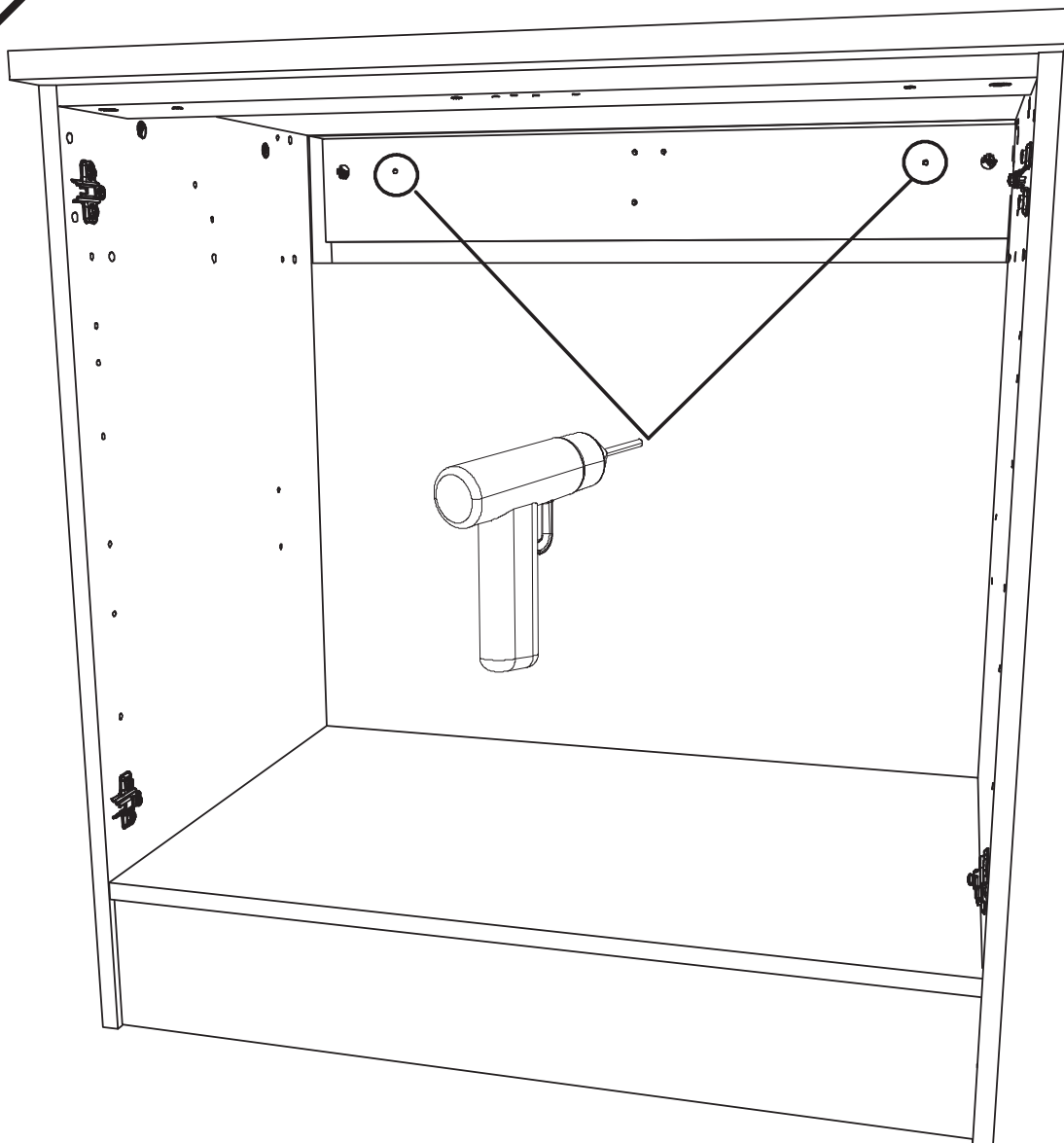
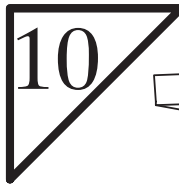
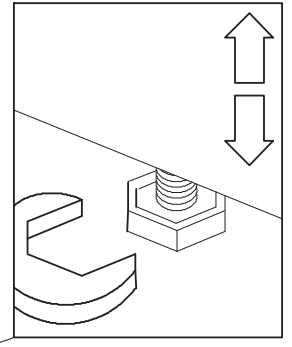
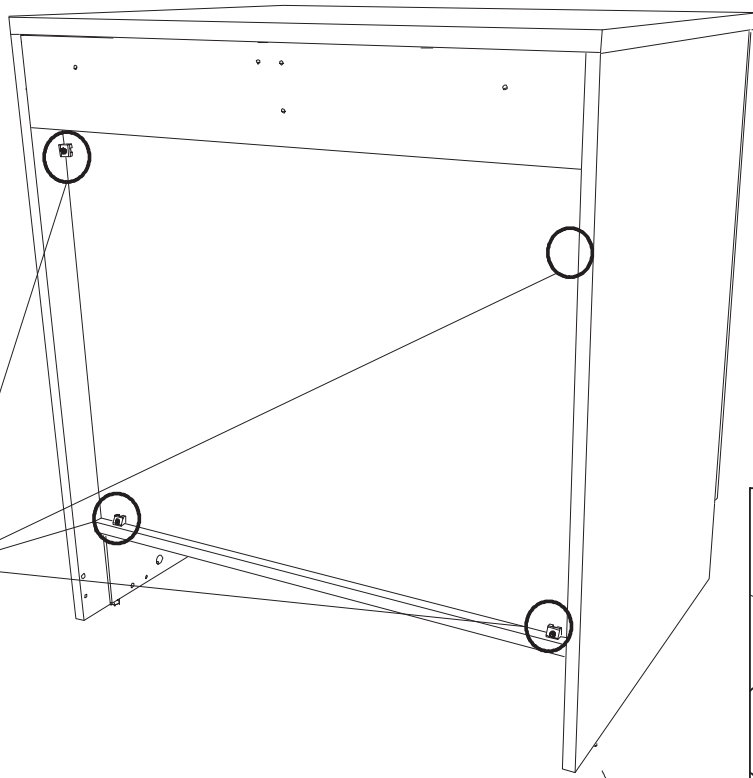
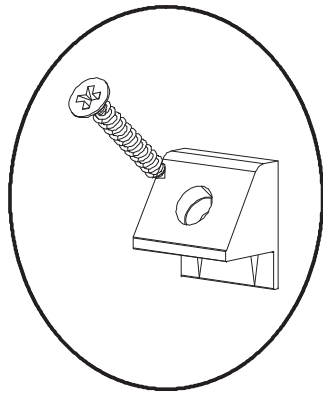
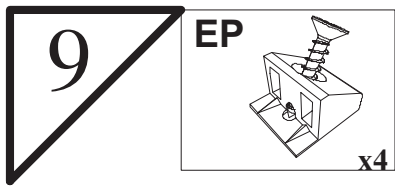

- FR Pour votre sécurité : Fixation du meuble au mur
Attention, la fixation doit être réalisée par une personne compétente car cela nécessite des chevilles adaptées à la nature de votre mur.
- EN For your safety: the unit should be secured to the wall.
NB this should be carried out by a competent person as you must use the right rawlplug for your type of wall.
- DE Zu Ihrer Sicherheit: Befestigen Sie das Hochbett an der Wand.
Achtung: Diese Befestigung ist durch eine fachlich kompetente Person vorzunehmen. Hierfür sind für die Bauweise Ihrer Wand geeignete Dübel einzusetzen.
- ES Por su seguridad: Fijar el mueble a la pared.
Advertencia: la fijación la ha de llevar a cabo por personal adecuado, ya que requiere el uso de tacos que se adapten al tipo de pared.
- PT Para sua segurança: fixação do móvel ao muro
Atenção: a fixação deverá ser efetuada por pessoa habilitada, visto que são necessárias cavilhas adaptadas ao tipo de parede.
- IT Avvertenza di sicurezza: il fissaggio del mobile a parete deve essere realizzato da una persona competente, in quanto l'operazione richiede l'impiego di tasselli adatti alla natura del muro.
- NL Voor uw veiligheid: bevestiging van het meubel aan de muur.
Opgelet de bevestiging moet worden uitgevoerd door een bekwaam persoon daar dit voor uw type muur geschikte pluggen vereist.
- CZ Z bezpečnostních důvodů: upevněte nábytek do zdi
Pozor, upevnění je třeba svěřit kompetentní osobě, neboť vyžaduje hmoždinky vhodné pro vaši zeď.
- HU Az Ön biztonsága érdekében : a bútor falra rögzítése
Figyelmeztetés : a rögzítés csak megfelelő szakképesítéssel rendelkező személy által végezhető el, mert a rögzítéshez a falnak megfelelő csavarokra van szükség.
- PL Dla bezpieczeństwa: mocowanie mebla do ściany
Uwaga, mocowanie musi zostać wykonane przez osobę kompetentną, ponieważ wymaga to zastosowania kołków dostosowanych do rodzaju ściany.
- RO Pentru securitatea dumneavoastră: fixarea mobilierului de perete
Atenție, fixarea trebuie să fie realizată de o persoană calificată, deoarece sunt necesare dispozitive de fixare adaptate caracteristicilor peretelui dumneavoastră
- RU Для вашей безопасности: Крепление мебели к стене
Внимание! Крепление должно производиться опытным специалистом, т.к. для такой установки потребуются шурупы, соответствующие типу вашей стены.
- SK Z bezpečnostných dôvodov: nábytok upevnite k stene.
Dbajte na to, aby upevnenie vykonal kompetentná osoba, pretože pri upevňovaní sa vyžadujú kolíky vhodné do materiálu, z ktorého je stena vyrobená.
- TR Güvenliğiniz için: Mobilyanın duvara sabitlemesi
Dikkat, sabitleme işlemi uzman biri tarafından yapılmalıdır çünkü bu işlem için duvarınızın malzemesine uygun dübellerin kullanılması gerekmektedir

ةيبرعلا ة

ةي صخشلا لكتمال سل : طئاحلا لىل ع ثاثل ة عطق تي بثت
ان يفسا بل طتت امنأ ذا طئاحلا لىل ع تي بثتلا ةي لم عب ص ص ختم ص خشر
هسفن طئاحلا ة ع يبط عم قفاوتي اني عم .

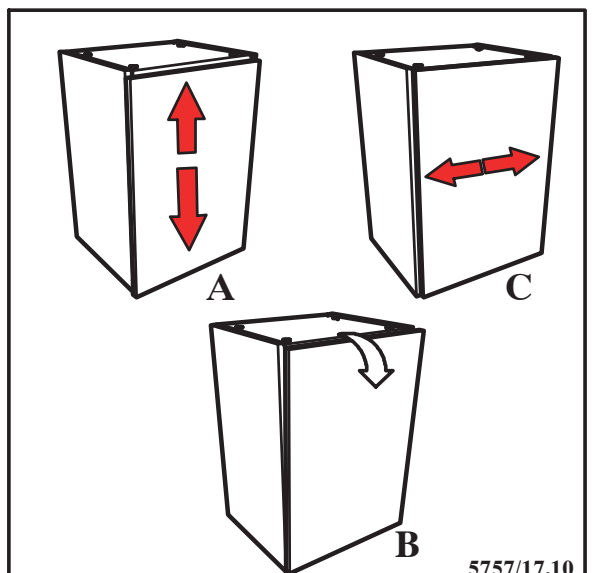
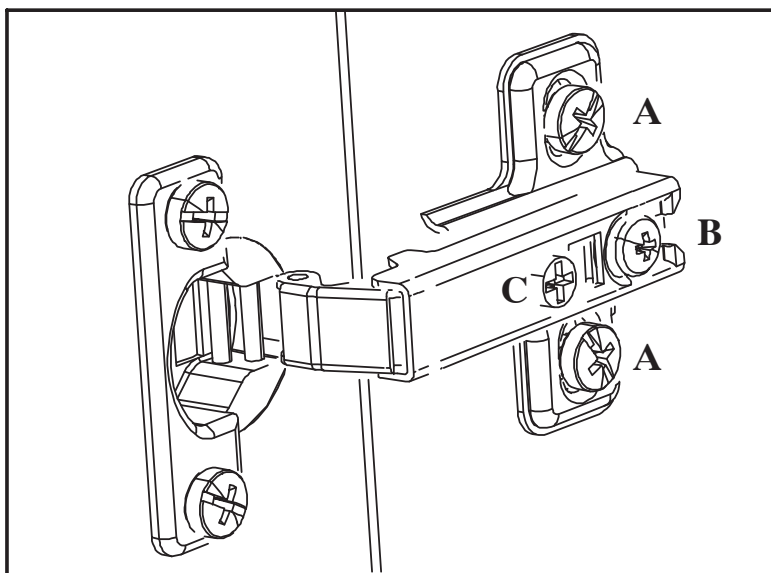
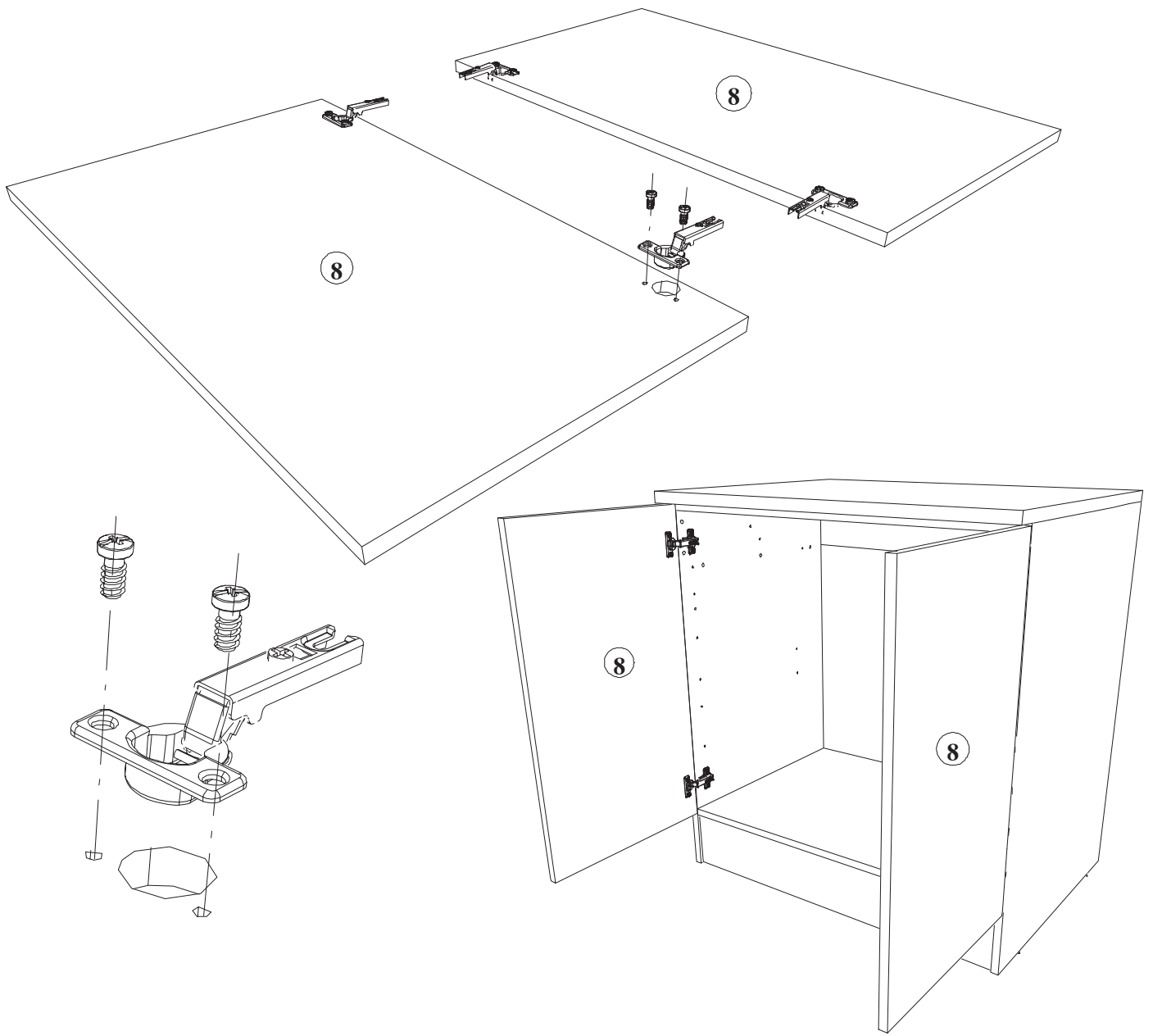
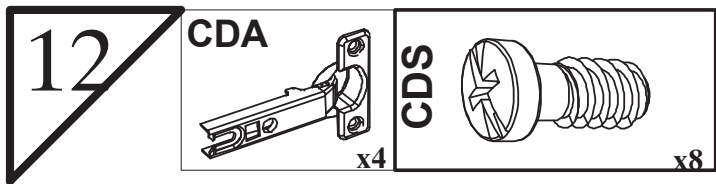

13

BWD



x4

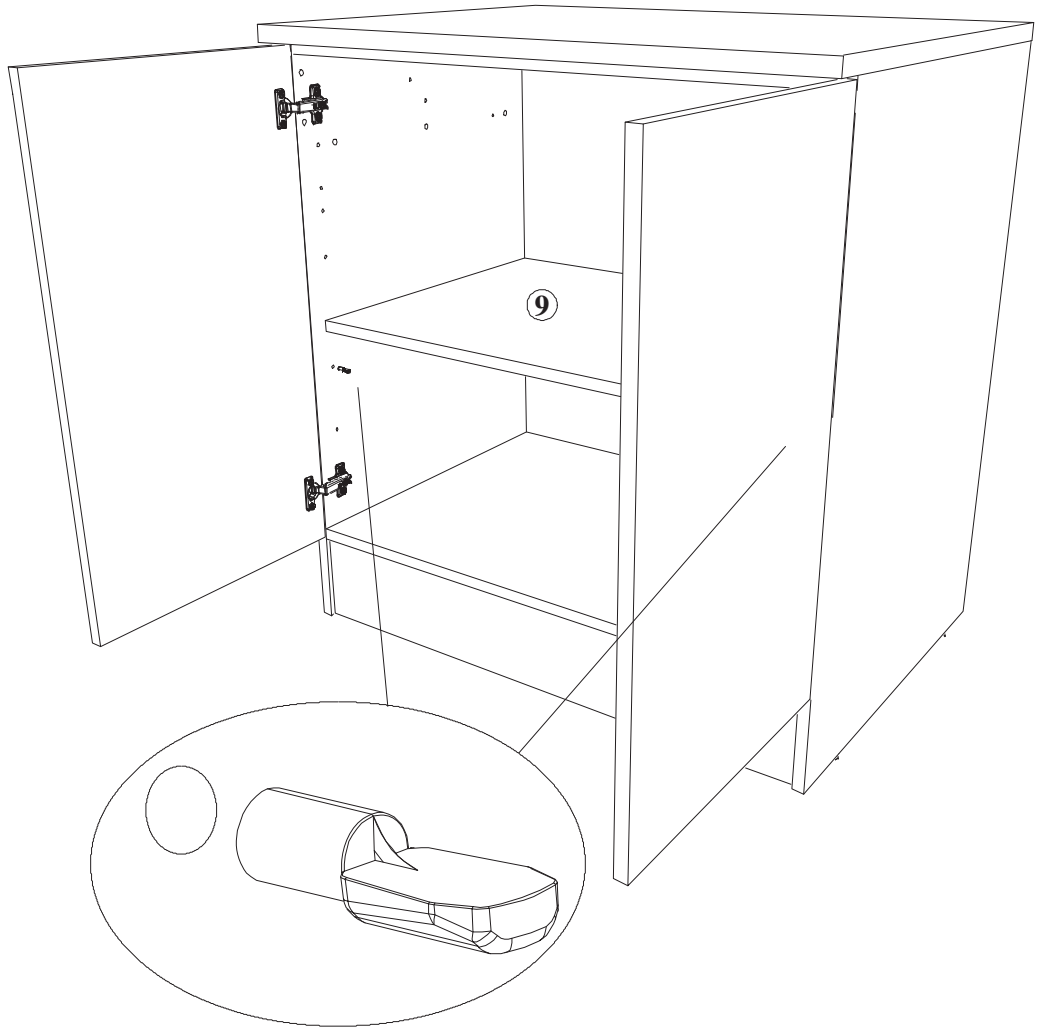

9

16mm

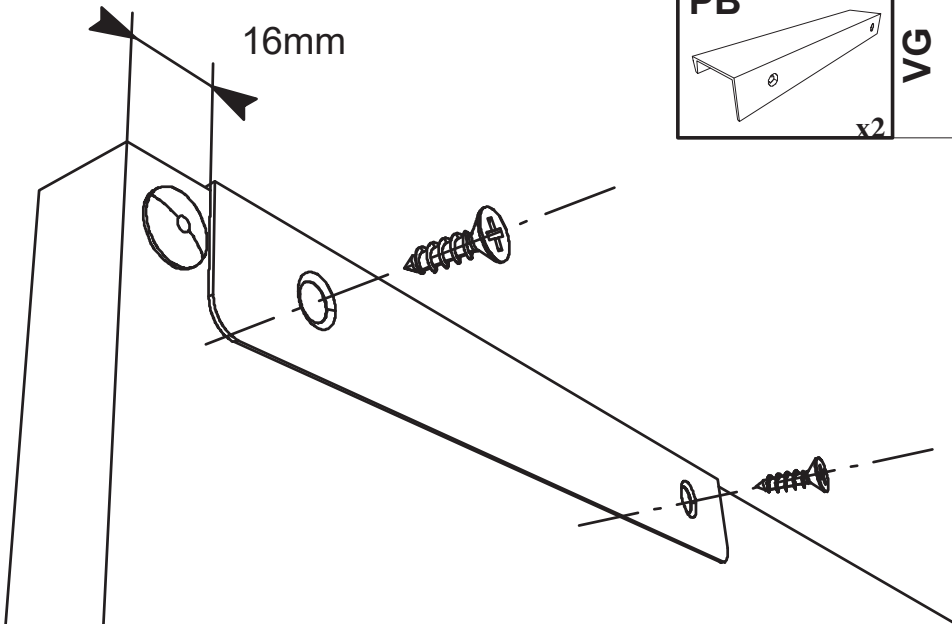

PB

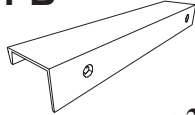

x2

VG

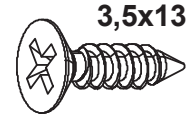

3,5x13

x4

PAS



x2



LE TRI + FACILE



FR

Pensez à donner ou recycler.



Association

ou



Magasin

ou



Déchèterie

<https://quefairedemesdechets.fr>