

Coffee Table

Installation Manual

Model NO. HC2

PRODUCT OVERVIEW

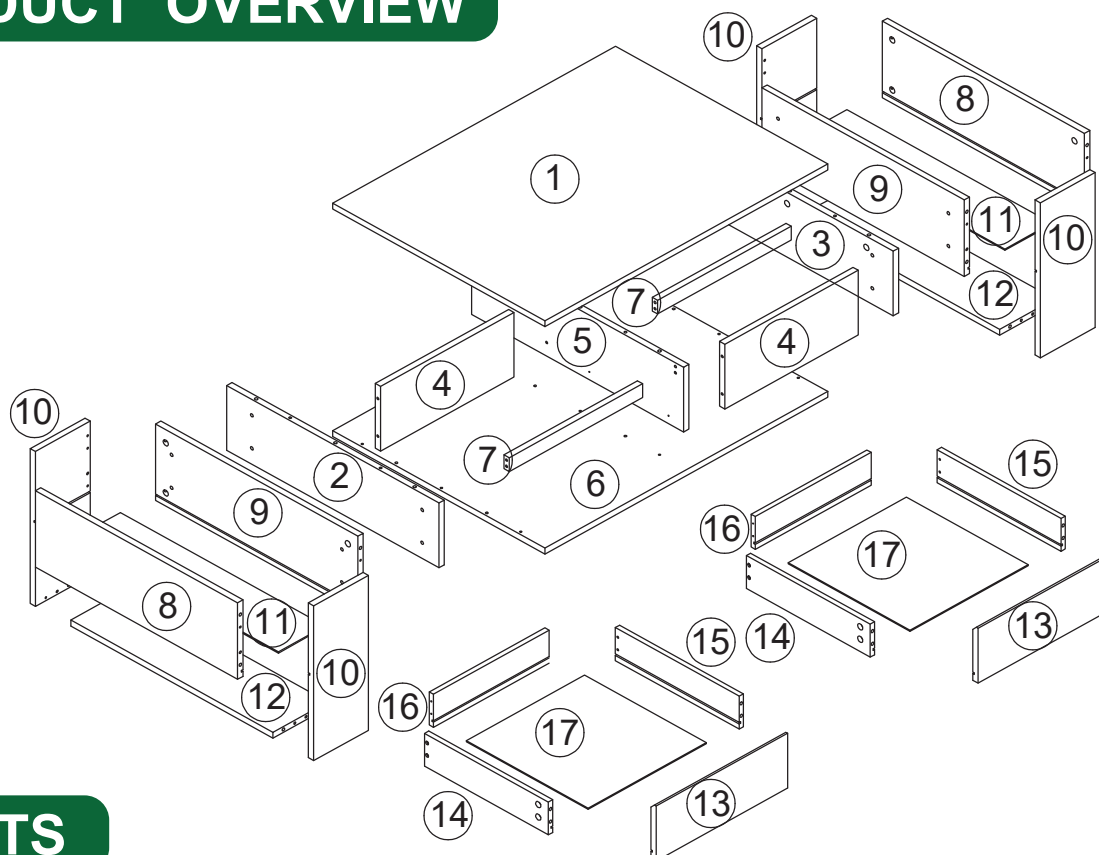

PARTS

Each part is marked with a small number, please correspond to the following diagram according to this number:

List

Ax41

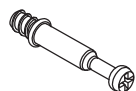

Bx41



Cx52

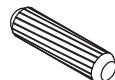

M6x30

Dx9



M4x40

Ex8



M4x30

Fx16



M3x12

Gx8

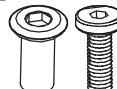

M6x15

Hx2

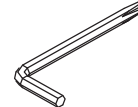

Ix24



Jx25



Kx8



CRx2



350mm

CLx2



350mm

DRx2



350mm

DLx2



350mm

ASSEMBLY INSTRUCTION

Do not tighten any single bolt before it is placed in the right position. After all the bolts are placed in the right position tighten them one by one orderly.

STEP1:

Diagram illustrating the assembly of four panels (10) using bolts (A). The panels are then joined to components (2) and (5) using bolts (F). The components (2) and (5) are secured with bolts (CL) and (CR).

Parts list for Step 1:

- CLx1 350mm
- CRx1 350mm
- Ax33
- Fx4 M3 x 12

STEP2:

Diagram illustrating the assembly of two vertical panels (8, 9) with components (12) and (10) using bolts (B, C). The panels are joined to components (12) and (10) using bolts (B) and (C).

Parts list for Step 2:

- Bx12
- Cx12 M6x30
- Ix8

STEP3:

Diagram illustrating the assembly of two vertical panels (8, 9) with components (12) and (10) using bolts (B, C). The panels are joined to components (12) and (10) using bolts (B) and (C).

Parts list for Step 3:

- Bx12
- Cx12 M6x30
- Ix8

STEP4:

Diagram illustrating the assembly of two vertical panels (8, 9) with components (12) and (10) using bolts (B, C). The panels are joined to components (12) and (10) using bolts (B) and (C).

Parts list for Step 4:

- Bx12
- Cx12 M6x30
- Ix8

STEP5:

Diagram illustrating the assembly of two vertical panels (8, 9) with components (12) and (10) using bolts (B, C). The panels are joined to components (12) and (10) using bolts (B) and (C).

Parts list for Step 5:

- Cx16 M6x30

STEP6:

Diagram illustrating the assembly of two vertical panels (8, 9) with components (12) and (10) using bolts (B, C). The panels are joined to components (12) and (10) using bolts (B) and (C).

Parts list for Step 6:

- Bx9
- Cx6 M6x30
- Jx9

STEP:7

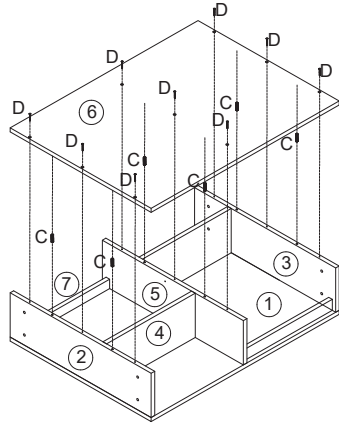

STEP:8

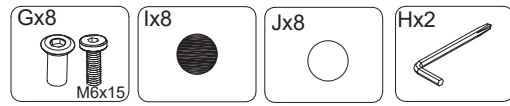
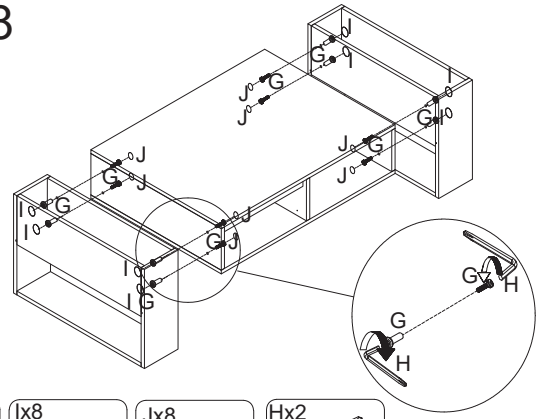

STEP:9

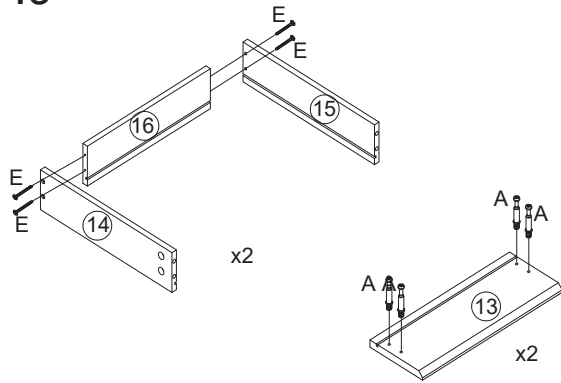

STEP:10

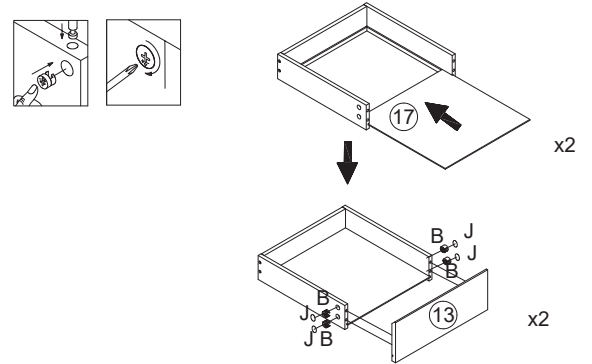

STEP:11

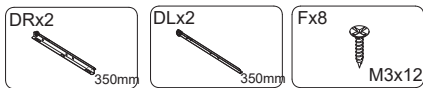
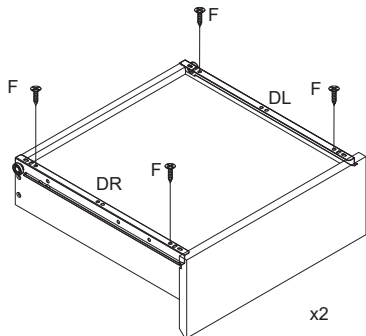

STEP:12

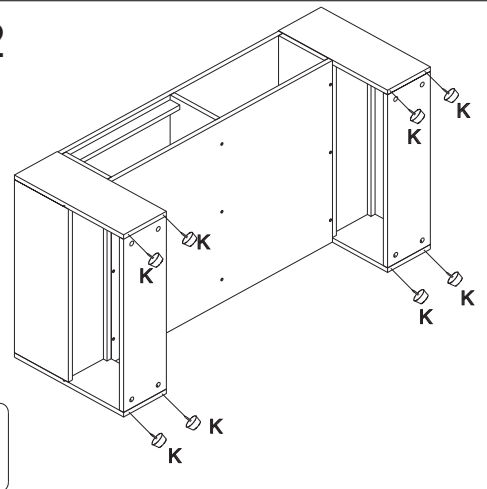

STEP:13

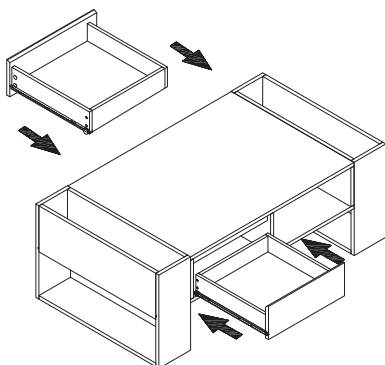

NOTICE

Please keep this instruction for future reference.

- Do not exceed the weight limit of this product 60KG.
 - Do not stand on or use any part of this item as a ladder.
 - Securely fasten all bolts, screws, and knobs before use.
 - Reconfirm the tightness of all bolts, screws, and knobs every 90 days.
 - Loosen screws during assembly. Do not tighten them until the item is fully assembled. If any components are missing, broken, damaged, or worn, stop using this product until repairs or replacements from the manufacturer's installation are made.
 - Do not use this product in a manner that is not in accordance with the manufacturer's instructions. If you have any questions or concerns, feel free to contact us at any time.
 - Product assembly must be performed on a clean, flat surface. We recommend covering your floor with packaging material (carton/cardboard) to protect the floor and product.
-

IN DE

Bitte behalten Sie diese Anleitung zur zukünftigen Verwendung.

Überschreiten Sie nicht das Gewichtslimit dieses Produkts 60KG.

Stehen Sie nicht auf oder verwenden Sie irgendeinen Teil dieses Artikels als Leiter.

Befestigen Sie alle Bolzen, Schrauben und Knöpfe vor dem Gebrauch sicher.

Bestätigen Sie alle Bolzen, Schrauben und Knöpfe alle 90 Tage erneut auf ihre Festigkeit.

Lösen Sie die Schrauben während der Montage. Ziehen Sie sie erst fest, wenn der Artikel vollständig montiert ist. Wenn Komponenten fehlen, gebrochen, beschädigt oder abgenutzt sind, verwenden Sie dieses Produkt nicht mehr, bis Reparaturen oder Ersatzteile von der Herstellerinstallation vorgenommen wurden. Verwenden Sie dieses Produkt nicht in einer Art und Weise, die nicht den Anweisungen des Herstellers entspricht. Bei Fragen können Sie sich gerne an uns wenden.

Die Produktmontage muss auf einer sauberen, ebenen Oberfläche erfolgen.

Wir empfehlen, Ihren Boden mit Verpackungsmaterial (Karton/Karton) abzudecken, um den Boden und das Produkt zu schützen.

IN FR

Veillez conserver cette instruction pour référence ultérieure.

Ne dépassez pas la limite de poids de ce produit 60KG.

Ne vous tenez pas debout sur ou n'utilisez aucune partie de cet objet comme une échelle.

Attachez solidement tous les boulons, vis et boutons avant utilisation.

Vérifiez à nouveau le serrage de tous les boulons, vis et boutons tous les 90 jours.

Desserrez les vis pendant l'assemblage. Ne les serrez pas avant que l'article ne soit entièrement assemblé. Si des composants sont manquants, cassés, endommagés ou usés, cessez d'utiliser ce produit jusqu'à ce que des réparations ou des remplacements soient effectués par le fabricant.

N'utilisez pas ce produit d'une manière qui n'est pas conforme aux instructions du fabricant. Si vous avez des questions ou des préoccupations, n'hésitez pas à nous contacter à tout moment.

L'assemblage du produit doit être effectué sur une surface propre et plane. Nous vous recommandons de recouvrir votre sol avec du matériel d'emballage (carton/carton) pour protéger le sol et le produit.

IN IT

Si prega di conservare queste istruzioni per riferimento futuro.

Non superare il limite di peso di questo prodotto 60KG.

Non stare in piedi o utilizzare alcuna parte di questo oggetto come scala.

Fissare saldamente tutti i bulloni, le viti e le manopole prima dell'uso.

Riconfermare la tensione di tutti i bulloni, le viti e le manopole ogni 90 giorni.

Allentare le viti durante il montaggio. Non stringerle fino a quando l'oggetto non è completamente assemblato. Se mancano componenti, sono rotte, danneggiate o usurate, smettere di utilizzare questo prodotto fino a quando non vengono effettuate riparazioni o sostituzioni dall'installazione del produttore. Non utilizzare questo prodotto in modo non conforme alle istruzioni del produttore. Se avrà domande o dubbi, si prega di contattarci in qualsiasi momento.

L'assemblaggio del prodotto deve essere eseguito su una superficie pulita e piana. Consigliamo di coprire il pavimento con materiale da imballaggio (scatola/cartone) per proteggere il pavimento e il prodotto.

Por favor, guarde estas instrucciones para futura referencia.

No exceda el límite de peso de este producto 60KG.

No se pare ni utilice ninguna parte de este artículo como escalera.

Enrosca firmemente todos los pernos, tornillos y perillas antes de usarlo.

Verifique nuevamente la firmeza de todos los pernos, tornillos y perillas cada 90 días.

Afloje los tornillos durante el montaje. No los apriete hasta que el artículo esté completamente ensamblado. Si falta alguna pieza, está rota, dañada o desgastada, deje de usar este producto hasta que se realicen las reparaciones o reemplazos proporcionados por la instalación del fabricante.

No utilice este producto de manera que no esté de acuerdo con las instrucciones del fabricante. Si tiene alguna pregunta o duda, no dude en contactarnos en cualquier momento.

El montaje del producto debe realizarse sobre una superficie limpia y plana. Recomendamos cubrir el piso con material de embalaje (cartón/cartón) para proteger el piso y el producto.



Thank you for choosing HOMAVO, welcome to communicate with us.
Email: Homavo-Official@outlook.com