

LC7877-LC0877-LA7877

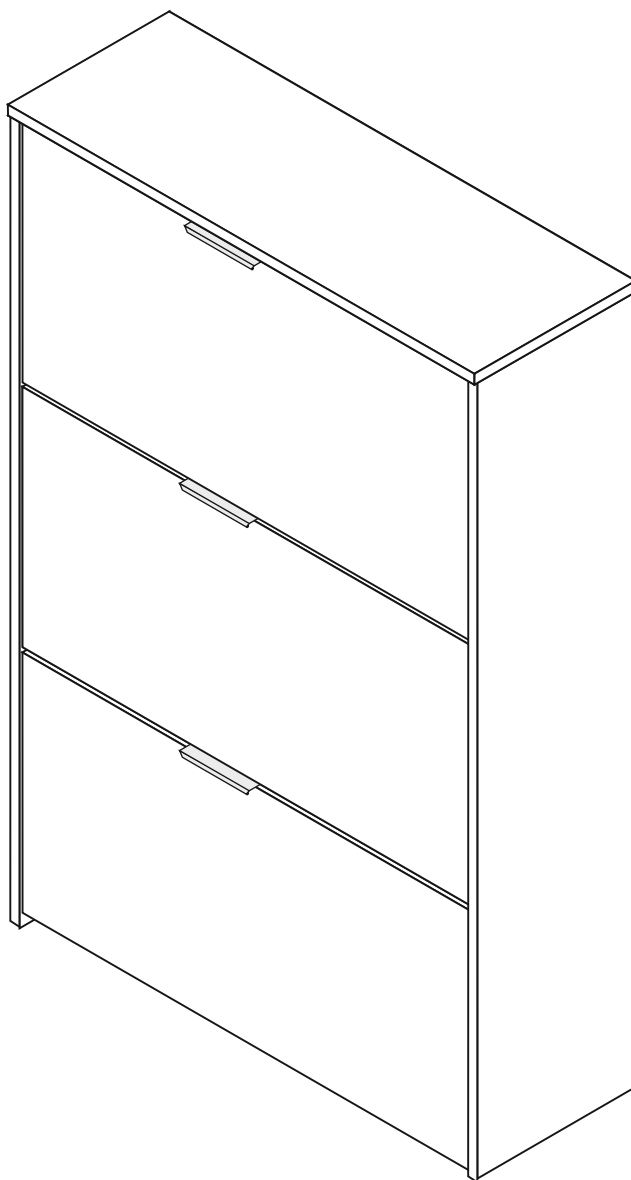

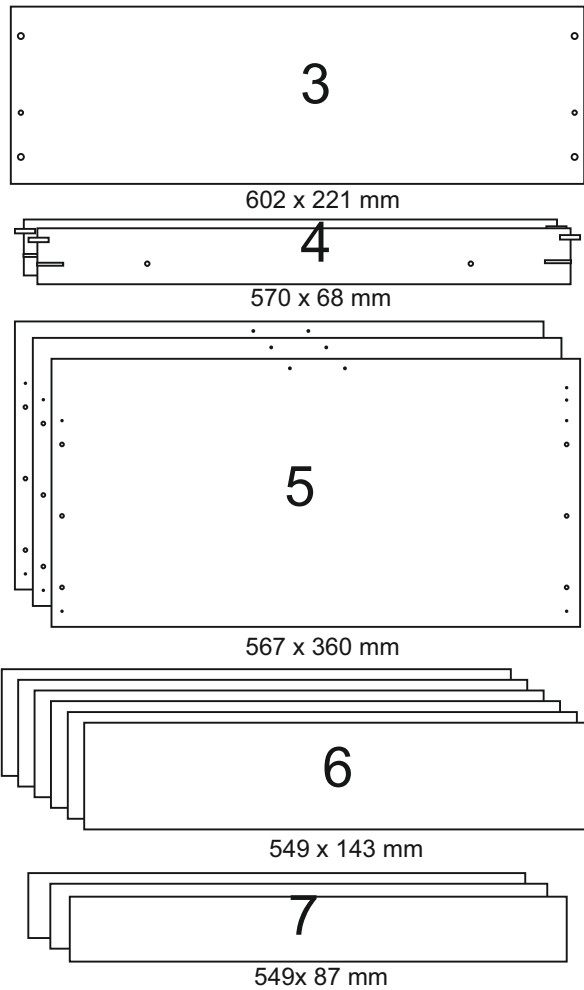

ZAPATERO 3 PUERTAS - SHOE'S CABINET 3 DOORS -
ARMOIRE À CHAUSSURES 3 PORTES - SAPATEIRA 3 PORTAS -
SCARPIERA 3 ANTE - SCHUHSCHRANK 3 FÄCHER -
ORMARIĆ ZA CIPELE 3 VRATA - AYAKKABI DOLABI 3 KAPILAR

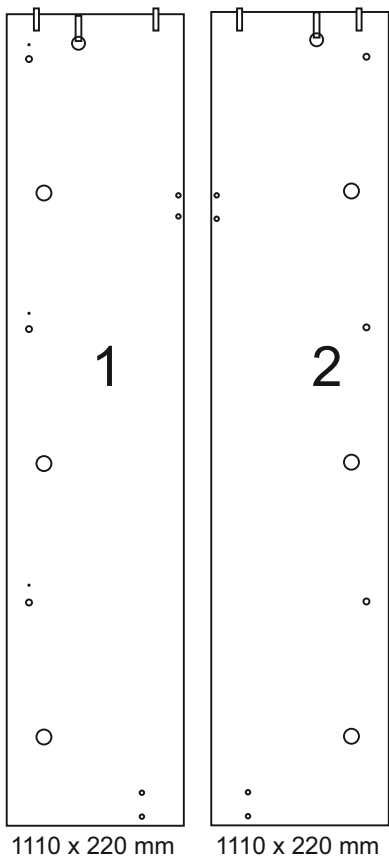
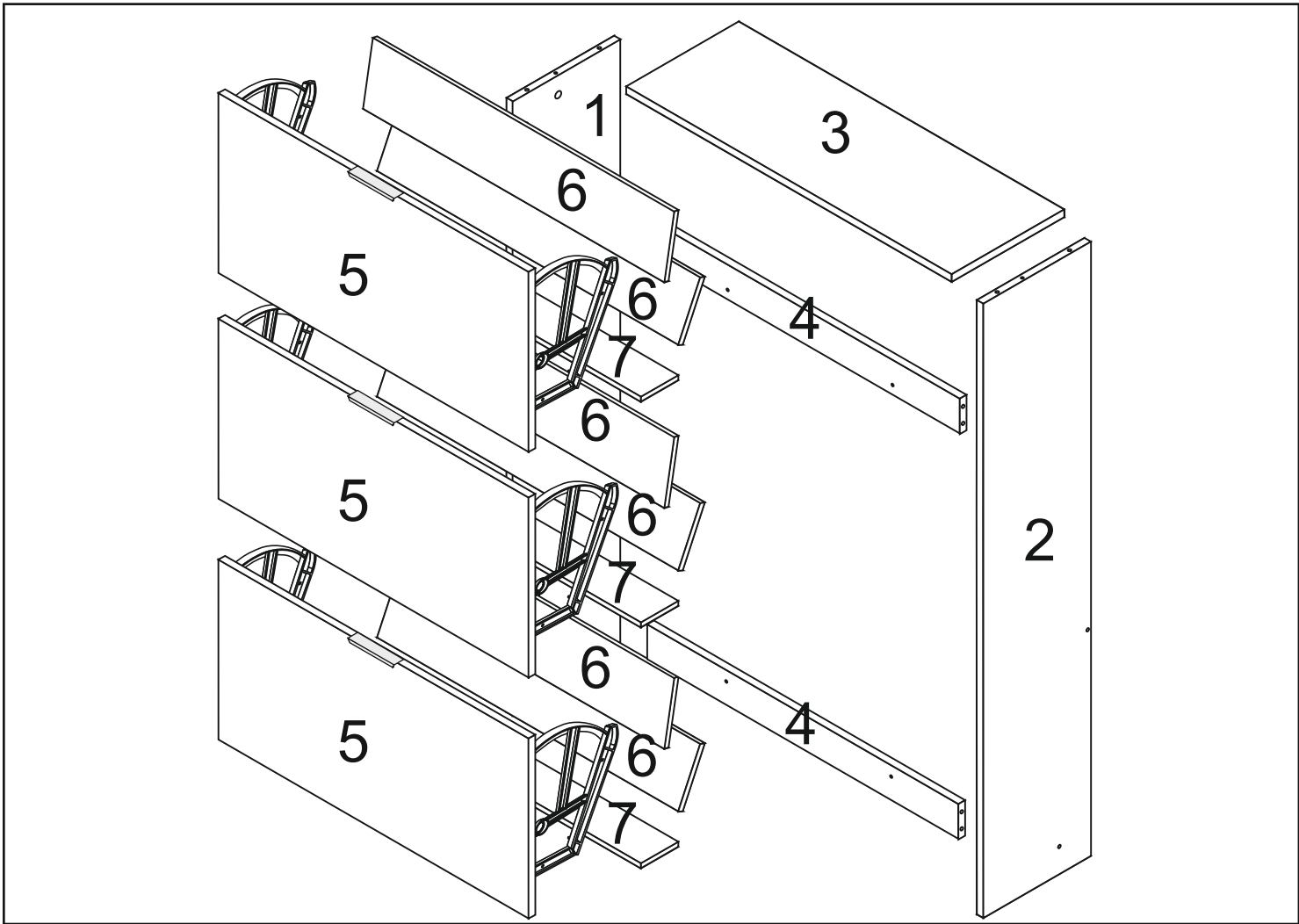

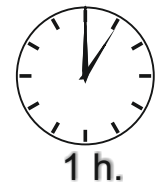
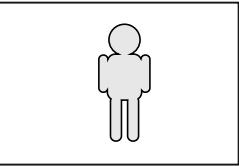
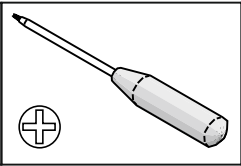
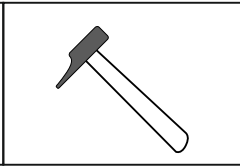
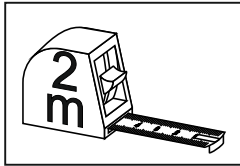



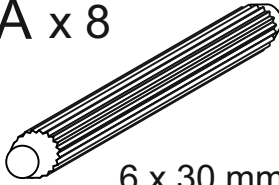
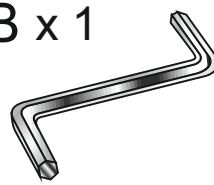
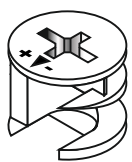
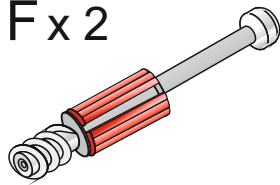
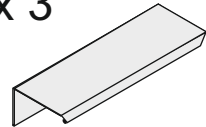
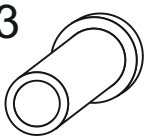
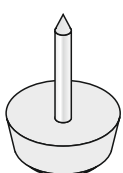
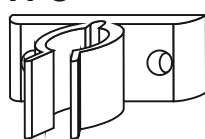

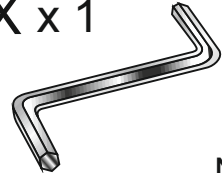
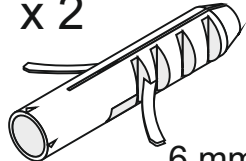
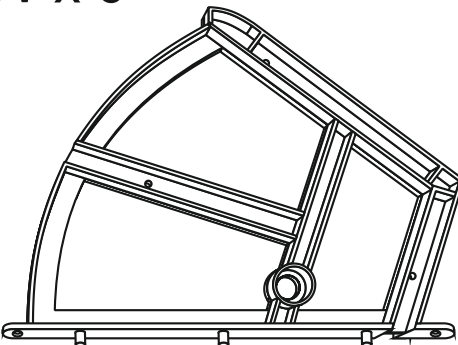
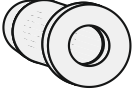
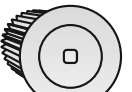
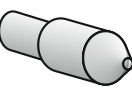
INSTRUCCIONES DE MONTAJE - ASSEMBLING INSTRUCTIONS - NOTICE DE MONTAGE - INSTRUÇÕES DE MONTAGEM -
ISTRUZIONI DI MONTAGGIO - MONTAGEANLEITUNG - UPUTE ZA MONTAŽU - MONTAJ TALÍMATI

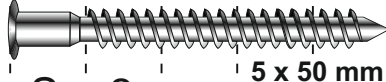

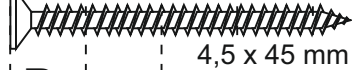





1 h.

A x 8  6 x 30 mm.	B x 1  n° 3	E x 2 	F x 2 
G x 3 	L x 3 	N x 4 	P x 3 
Q x 4  3 mm.	X x 1  N° 4	Z x 2  6 mm.	
W x 6    			

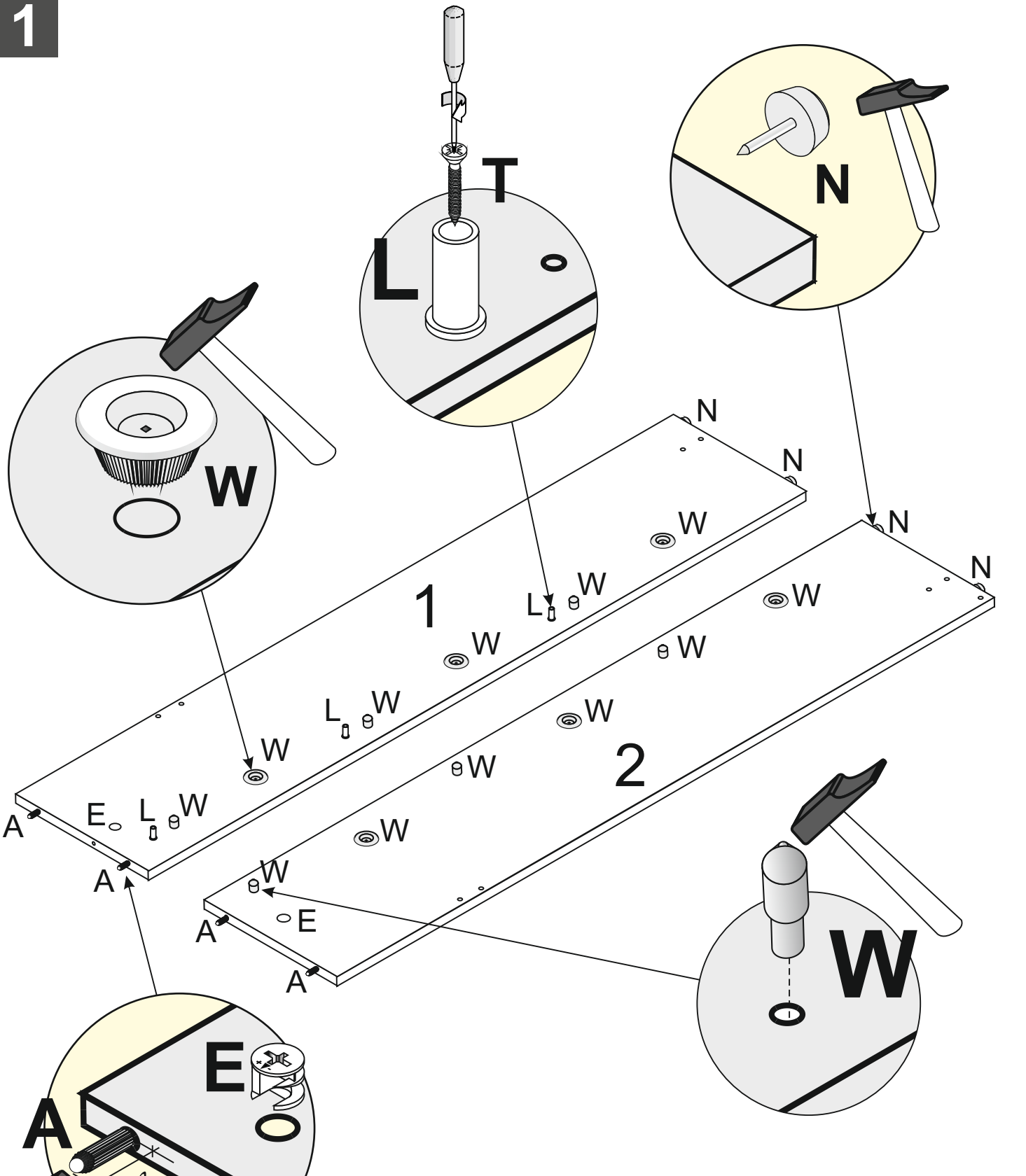
	0	1 cm.	2	3	4	5
	C x 4					
		5 x 50 mm				
	S x 2					
		4,5 x 45 mm				
	R x 42					
		3 x 15 mm				
	T x 3					
		3,5 x 22 mm				
	Y x 6					
		6 x 11 mm				

1

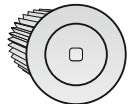
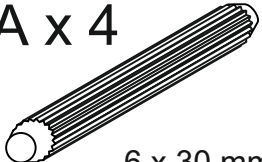

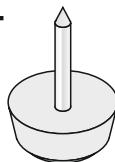
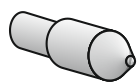
<p>T x 3</p>  <p>3,5 x 22 mm</p>	<p>L x 3</p> 	<p>W x 6</p> 
<p>A x 4</p>  <p>6 x 30 mm</p>	<p>E x 2</p> 	<p>N x 4</p> 
		<p>W x 6</p> 

2

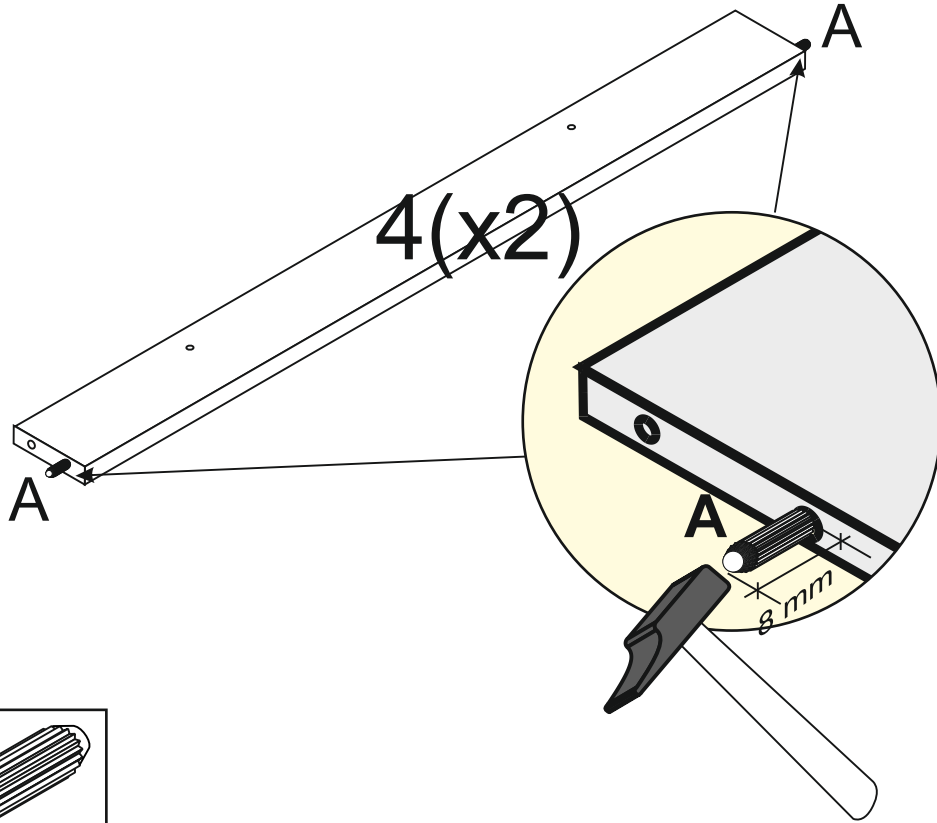

A x 4

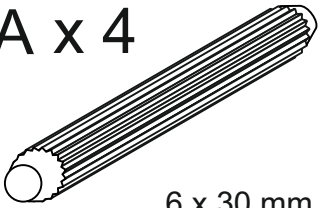

3

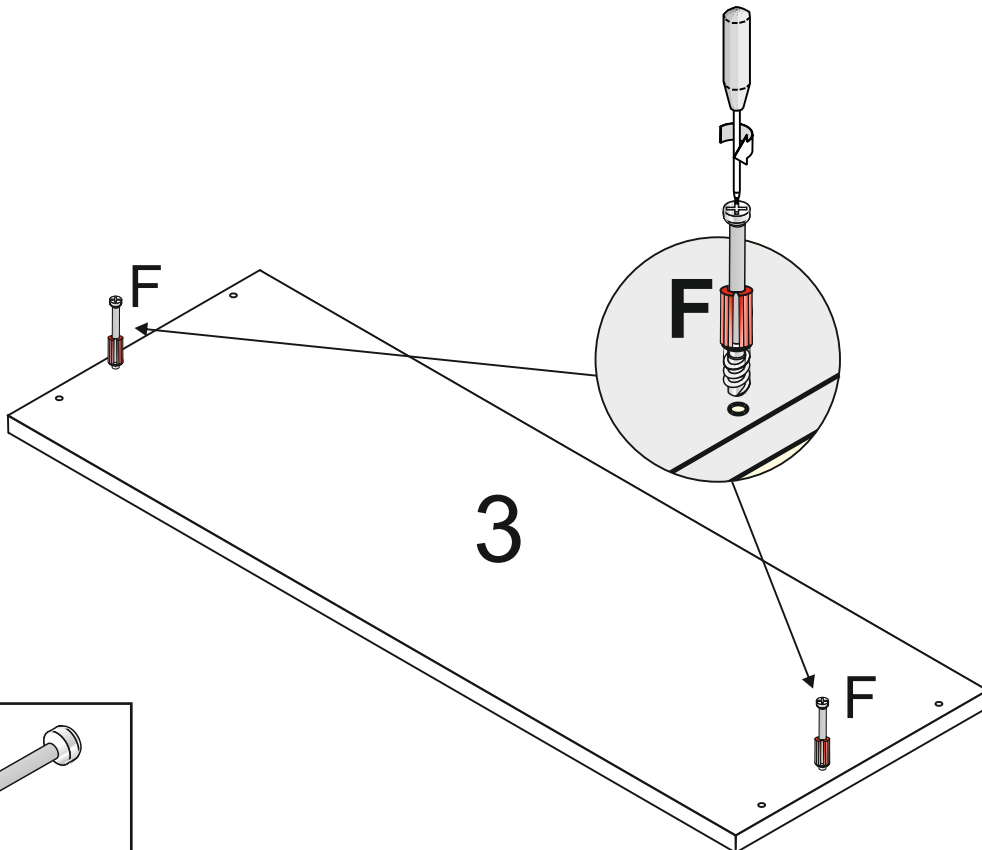

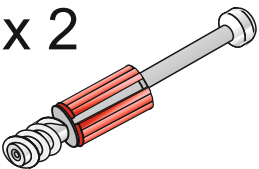

F x 2

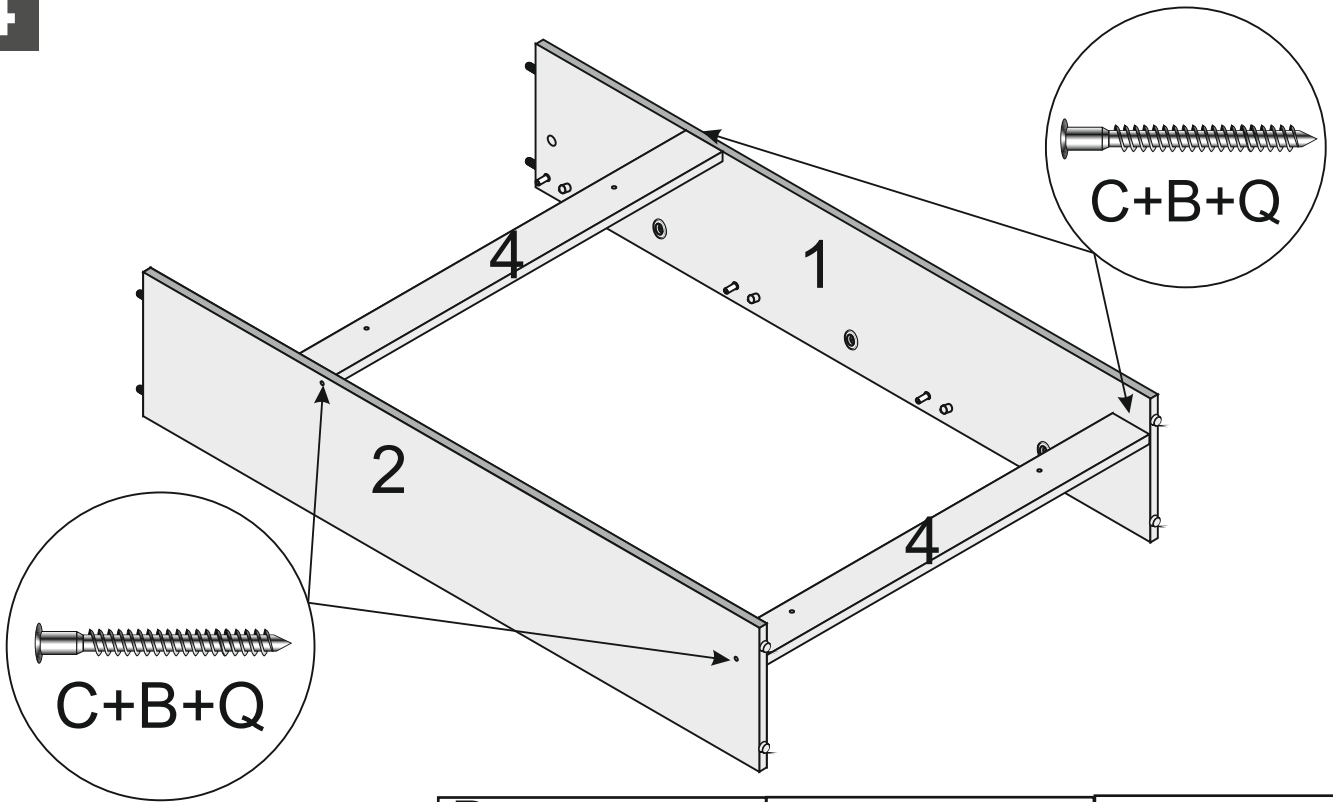

4

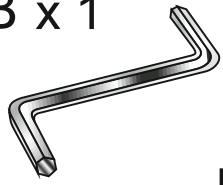
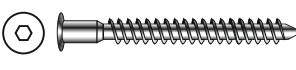

<p>B x 1</p>  <p>n° 3</p>	<p>C x 4</p>  <p>5 x 50 mm</p>	<p>Q x 4</p>  <p>3 mm.</p>
---	--	---

5

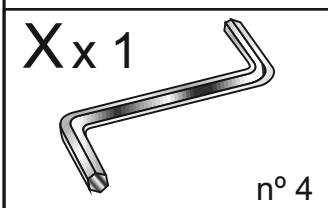
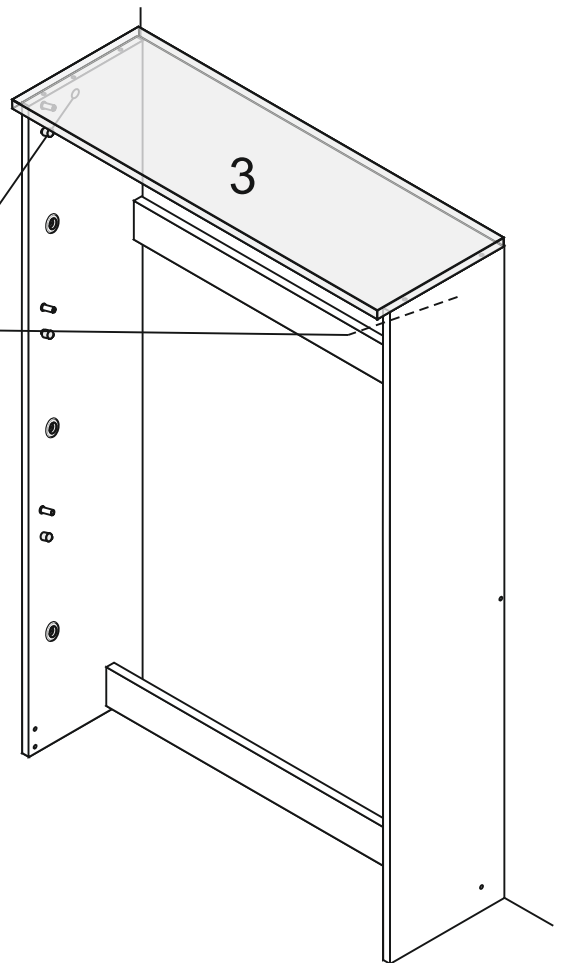
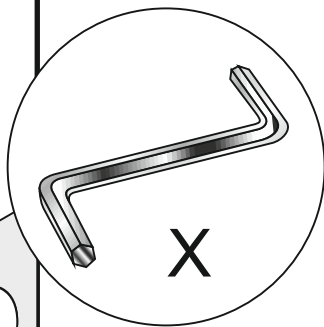
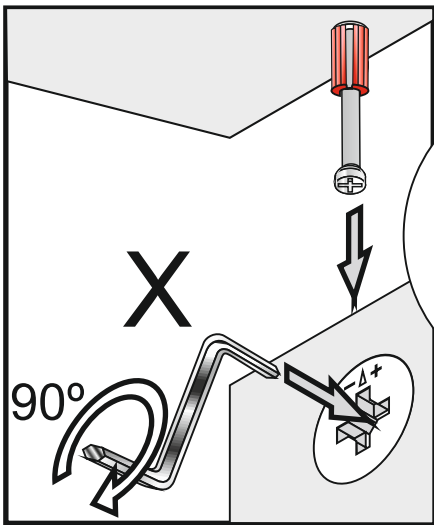

6

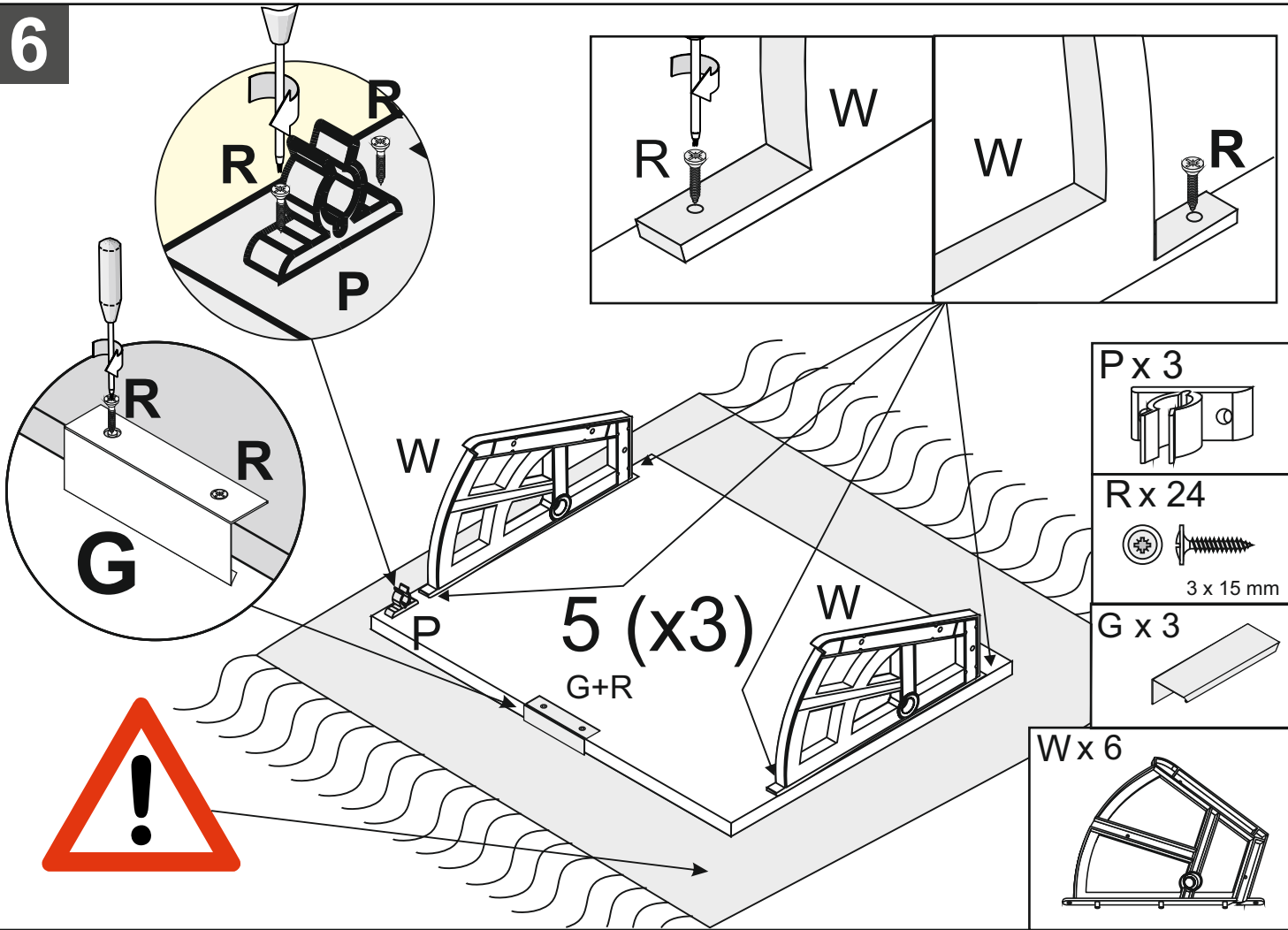

7

(x3)

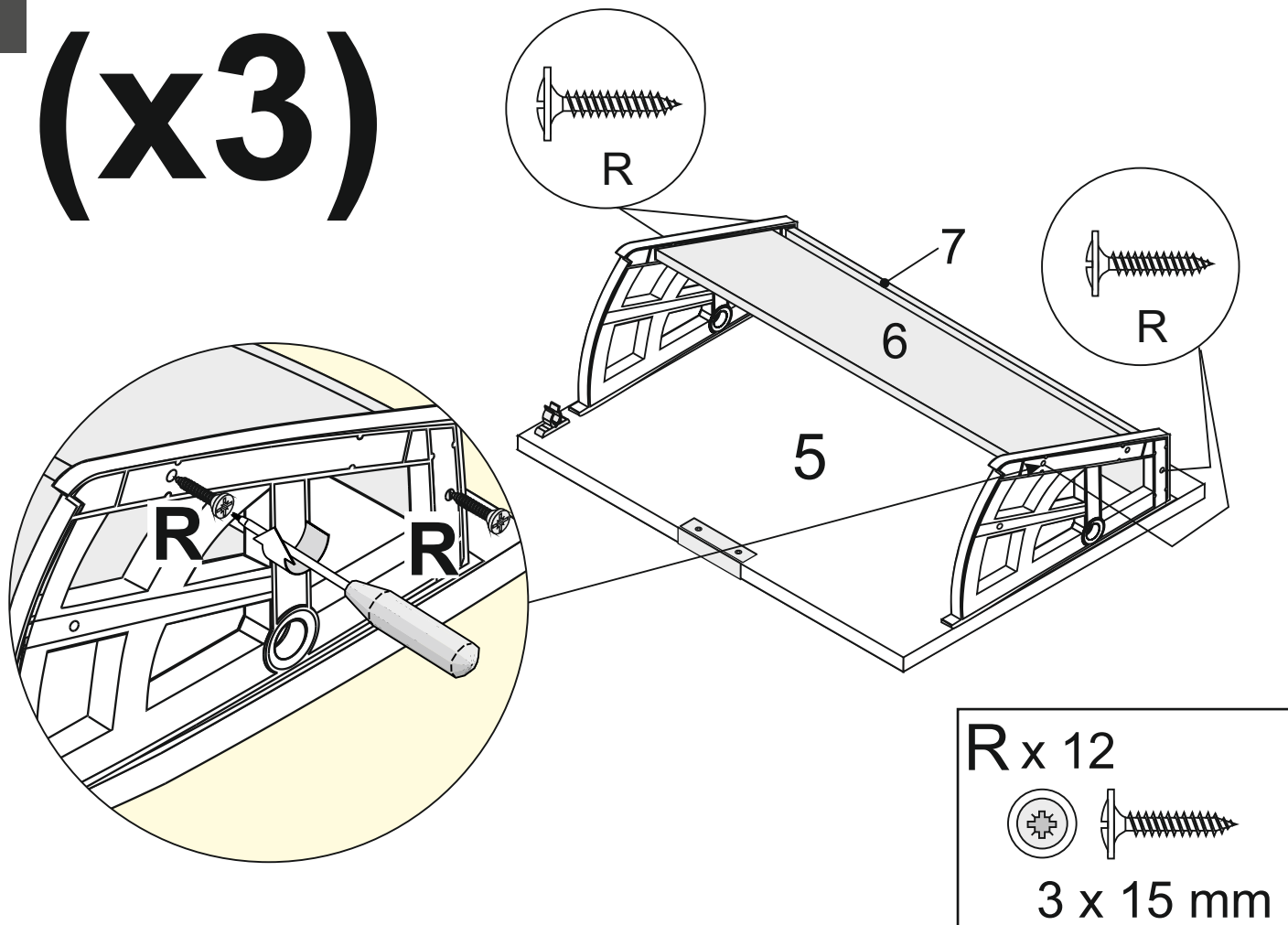

8

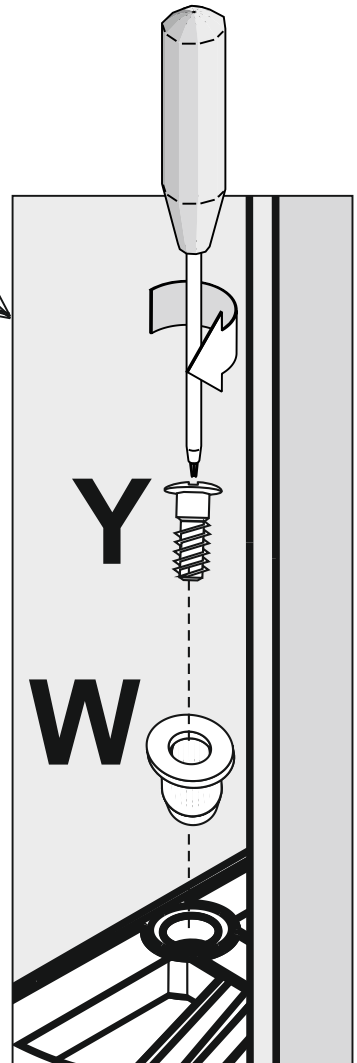
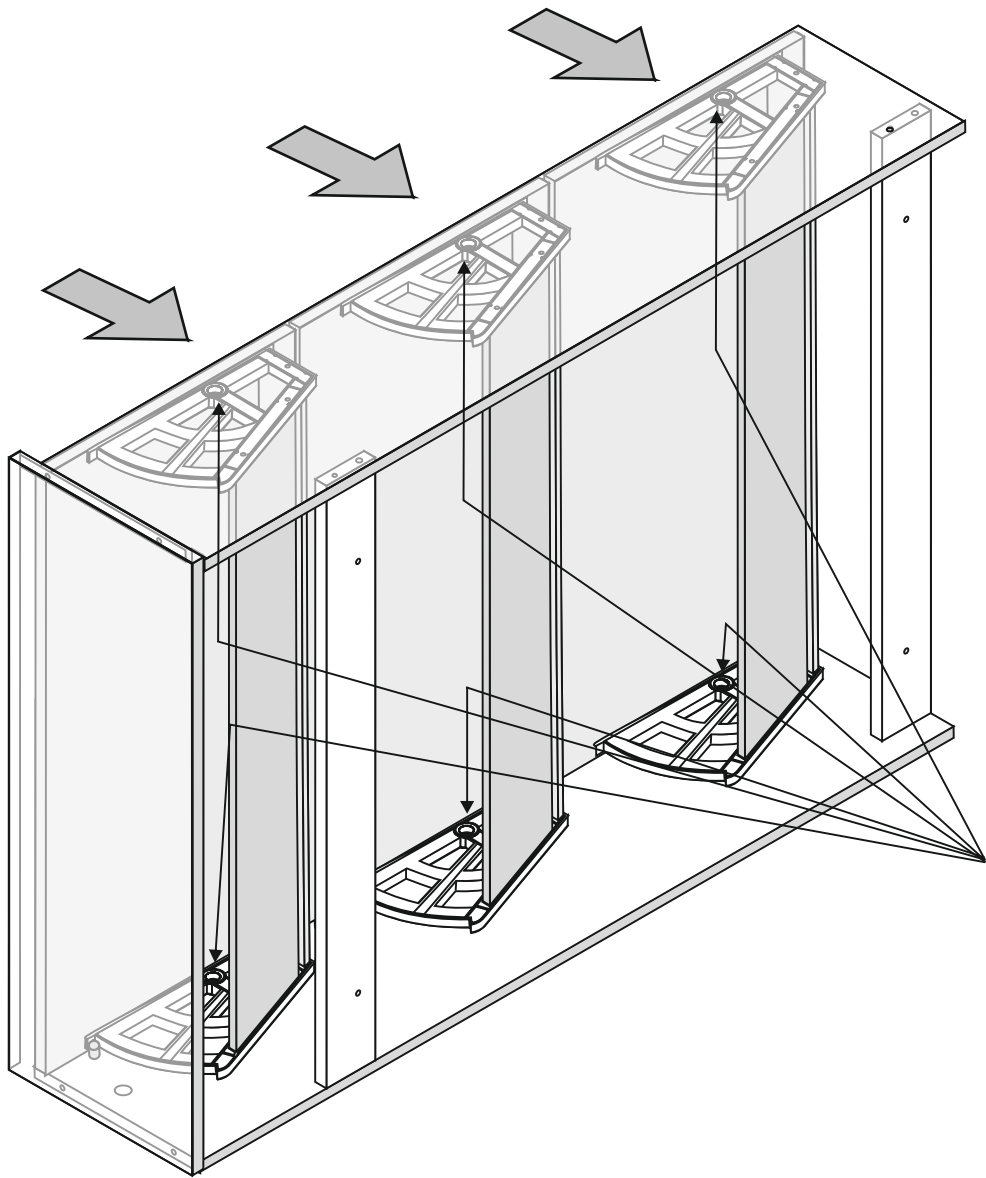

W x 6

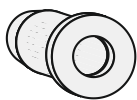

Y x 6

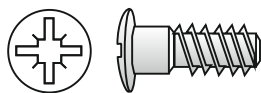

6 x 11 mm

9

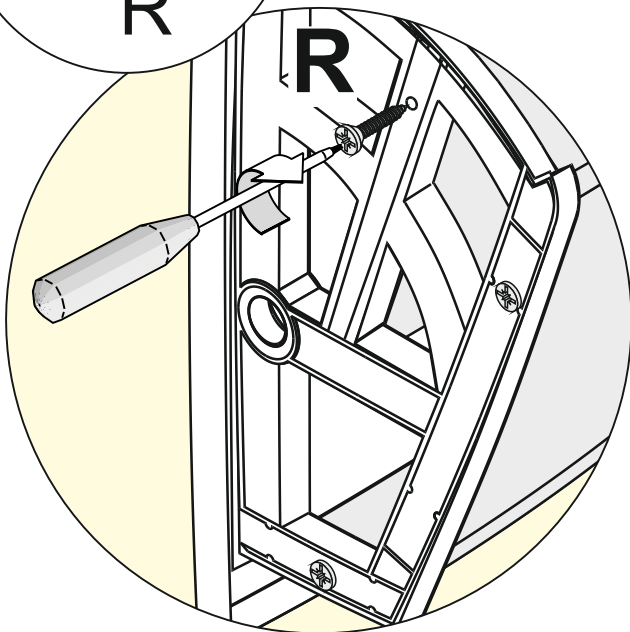
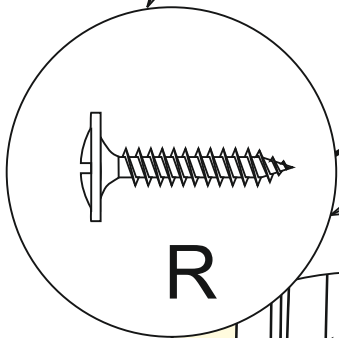
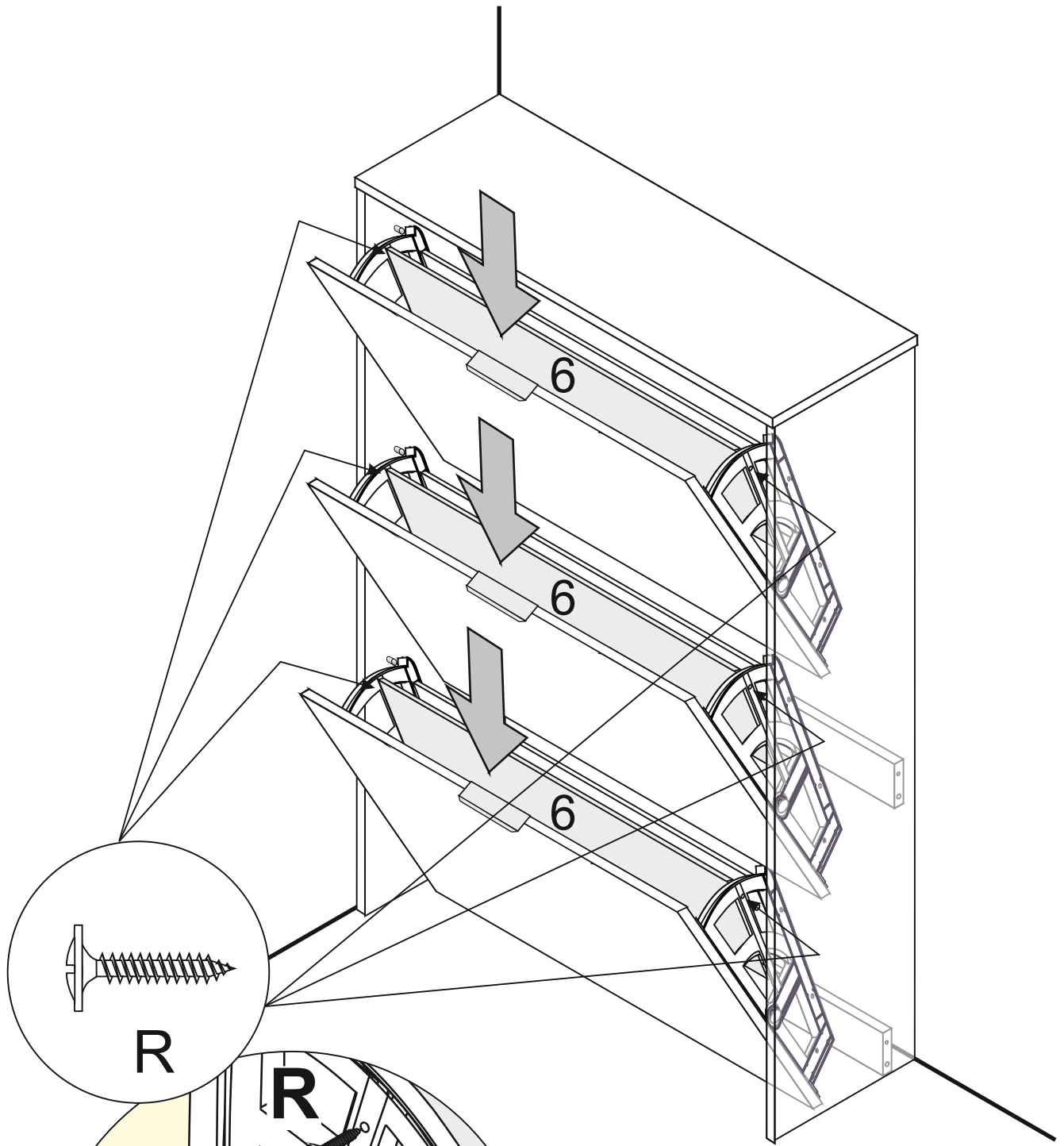

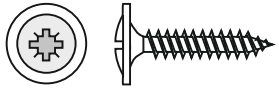

R x 6



3 x 15 mm

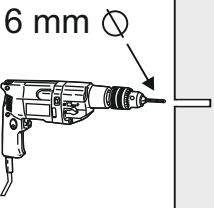
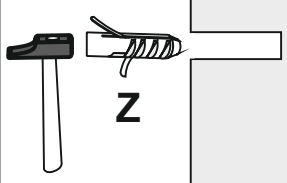

- ES** · USE HERRAJES ADECUADOS PARA EL MATERIAL DE LAS PAREDES DE SU CASA
- EN** · USE FIXING DEVICES SUITABLE FOR THE WALLS IN YOUR HOME
- FR** · UTILISEZ DES FIXATIONS ADAPTÉES AU MATÉRIAU DU MUR
- PT** · UTILIZE FERRAGENS ADEQUADAS ÀS PAREDES DA SUA CASA
- IT** · USA SISTEMI DI FISSAGGIO ADATTI ALLE PARETI DELLA TUA CASA
- DE** · BEFESTIGUNGSBESCHLÄGE BENUTZEN, DIE FÜR DIE HEIMISCHEN WÄNDE GEEIGNET SIND
- HR** · UPOTRIJEBITE PRIČVRSNIKE PRIKLADNE ZA ZIDOVE VAŠEG DOMA
- TR** · EVINIZIN DUVAR YAPI MALZEMESINE UYGUN BAĞLANTI PARÇALARI SEÇİNİZ

	1)
	2)
	3)
	4)

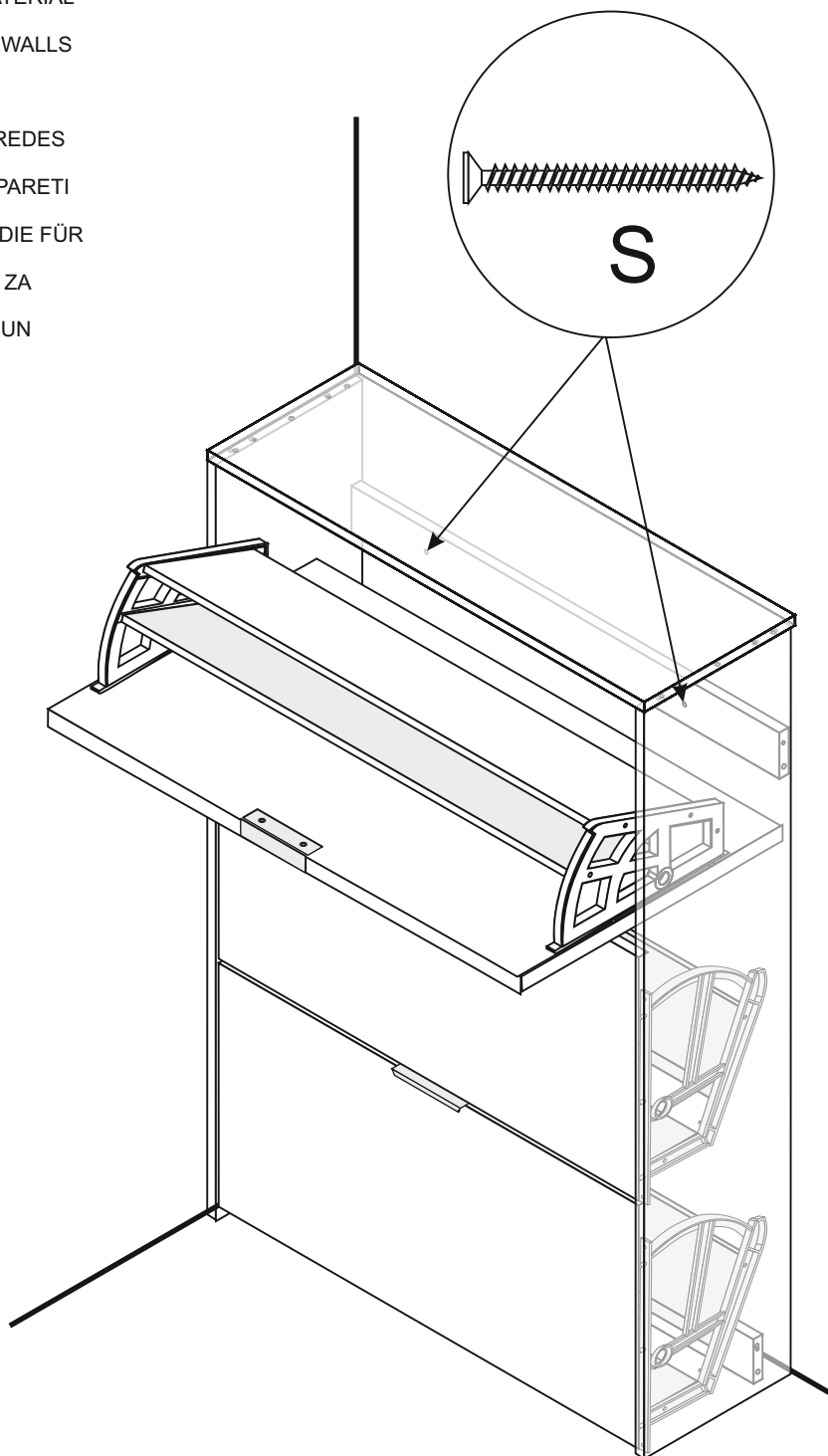

S x 2



4.5 x 45 mm.

Z x 2

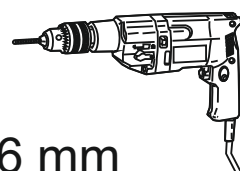
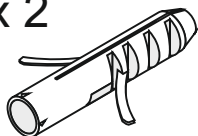

6 mm

ES**RECOMENDACIONES PARA EL MONTAJE Y PARA EL USO**

- Preparar las piezas que constituyen el mueble
- Reagrupar y contar el herraje
- Preparar las herramientas necesarias
- Preparar la zona de montaje
- Realizar el montaje sobre una moqueta para evitar rayar el mueble
- No forzar nunca los ensamblajes
- No colocar cerca de fuentes de calor
- No utilizar paños, trapos o productos de limpieza que puedan rayar la superficie del mueble
- Mueble apto para uso doméstico. Ubicación en el interior de la vivienda

EN**RECOMMENDATIONS FOR FITTING AND FOR USE**

- Prepare the pieces of furniture to make it up
- Group up and count the iron parts, screws... etc.
- Prepare the necessary tools
- Prepare the fitting place
- Do the fitting on a carpet so you don't damage the furniture
- Never force the fitting
- Do not put near to any sort of heat
- Do not use cloths or cleaning products that could damage the surface of the furniture
- Furniture suitable for domestic use, keep indoors

FR**CONSEILS DE MONTAGE ET POUR L'USAGE**

- Identifier les différents panneaux
- Regrouper et compter la quincaillerie
- Munissez-vous de l'outillage nécessaire
- Aménagez-vous une zone de montage. La moquette ou une couverture protégera des rayures
- Ne jamais forcer le montage
- Ne pas placer près des sources de chaleur
- N'utilisez pas de chiffons ou des produits de nettoyage qui puissent rayar la superficie du meuble
- Meuble apte pour l'usage domestique, on peut le placer à l'intérieur de la maison

PT**AVISO PARA MONTAGEM E PARA USO**

- Preparar as peças que compõem o móvel
- Reagrupar e contar as ferragens
- Preparar as ferramentas necessárias
- Preparar o local para a montagem
- Efetuar a montagem sobre uma alcatifa para evitar arranhar o móvel
- Não forçar nunca a ensambladura
- Não colocar perto de fontes de calor
- Não utilizar panos, trapos ou produtos de limpeza que possam riscar a superfície do móvel
- Móvel apto para o uso doméstico. Colocação no interior da vivenda

IT**CONSEGLI PER L'INSTALLAZIONE E L'USO**

- Preparate i componenti del mobile per il montaggio
- Ordinate e controllate la quantità della ferramenta
- Preparate gli attrezzi necessari
- Preparate un luogo idoneo al montaggio. Sistemate i componenti su un tappeto per non danneggiare le superfici
- Non forzate mai i componenti
- Non posizionate il mobile vicino a fonti di calore
- Non usate panni abrasivi né detersivi né solventi che possano danneggiare le superfici
- Questo prodotto è solo per uso domestico, non professionale. Non adatto per uso all'aperto

DE**MONTAGEHINWEISE UND GEBRAUCHSHINWEISE**

- Sortieren und identifizieren Sie die Einzelteile
- Überprüfen Sie die Anzahl der einzelnen Beschlagteile
- Legen Sie das notwendige Werkzeug bereit
- Einen montagebereich freimachen
- Montieren Sie das Möbel auf einem ebenen, weichen, sauberen Untergrund
- Niemals die verbindungen zu stark anziehen
- Nicht neben Wärmequellen platzieren.
- Für die Reinigung verwenden Sie bitte ein weiches Tuch und keinesfalls scharfe oder ätzende Reinigungsmittel.
- Das Möbel ist ausschließlich für den Gebrauch im Haus geeignet.

HR**PREPORUKE ZA MONTAŽU I ZA UPORABU**

- Pripremite komada namještaja za montiranje
- Pripremite sve dijelove namještaja.
- Pripremite potrebne alat
- Pripremite prostor za montažu
- Učinite montažu na tepihu, tako da ne oštetiți namještaj
- Nemojte upotrebljavati silu prilikom sklopanja
- Ne stavljajte blizu bilo kakve topline
- Ne koristite krpe ili proizvode za čišćenje koji bi mogli oštetiți površinu namještaja
- Namještaj prikladni za kućnu uporabu.
- Položaj unutar kućišta

TR**ÖNERİLER MONTAJ VE KULLANIM**

- Mobilyaları parçaları hazırlayın
- Grubu yukarı ve saymak demir parçaları,vidalar vb...
- Gereklî araçları hazırlayın
- Bir montaj alanı hazırlama
- Eđer mobilya zarar vermeyecek şekilde bir halî üzerinde uydurma yapın
- Montajları zorlamayınız
- Isı her türlü yakın koymayın
- Bezler veya olabılır temizlik ürünleri kullanmayın mobilya yüzeyine zarar
- Ev kullanımı için uygun mobilya. Konumu evin içinde

GARANTÍA - GUARANTEE - GARANTIE - GARANTIA - GARANZIA - GARANTIE - JAMČITI - GARANTISI

ES · Fabricado en U.E. por FORES DISEÑO S.L. C.I.F: B-12313003 - Ctra.Nac.232; Km 11,1 C.P. 12320 - Sant Jordi (Castellón) SPAIN - el cual garantiza este producto por un periodo de **2 años** a partir de la fecha de compra, contra todo defecto de fabricación.

· Si se encuentra alguna dificultad a la hora del montaje o existe algún defecto en el mueble, puede contactar con nosotros al **964 46 52 22** o por e-mail: **postventa@fores.es** donde gustosamente atenderemos todas sus consultas. HORARIO: de lunes a viernes de 9h a 14h y de 15h a 18h.

· Esta garantía no ampara los defectos producidos por un mal montaje, utilización indebida o mal uso del mueble.

· Es imprescindible conservar el **ticket** de compra y facilitar el **Nº de Control de Calidad** para cualquier consulta o reclamación.

EN · Manufactured in Spain by FORES DISEÑO S.L. CIF B-12313003-ctra Nac 232 km 11.1 C.P.12320-Sant Jordi, (Castellón) SPAIN - Guarantee of **2 years** from date of purchase against any fault of production.

· If a difficulty when assembly or a fault in the product is found you can contact us at **(+34) 964 46 52 22** or by email: **postventa@fores.es** where we will be pleased to help you. TIMETABLE: Monday until Friday 9-14h / 15-18h.

· The Guarantee does not cover the faults produced by an incorrect assembly or misuse of the furniture.

· Indispensable to keep the purchase **ticket** and facilitate the **Nº of Quality Control** for any consult or claim.

FR · Fabriqué en UE par FORES DISEÑO S.L. CIF B-12313003 – Ctra Nac 232; Km 11,1 CP12320 – Sant Jordi (Castellón) Espagne – Celui ci garantie ce produit pour une période de **2 ans** à partir de la date d'achat, contre tout défaut de fabrication.

· Si vous rencontrez une quelconque difficulté à l'heure du montage ou si il y a un défaut sur le meuble, vous pouvez nous contacter par téléphone au **(+34) 964 46 52 22** ou bien par e-mail à **postventa@fores.es** où nous aurons le plaisir de vous accueillir pour toutes demandes. Nos HORAIRES sont du lundi au vendredi de 9H00 à 14H00 et de 15H00 à 18H00.

· Cette garantie ne couvre pas les défauts résultants d'un mauvais montage, d'une utilisation indue ou d'un mauvais usage du produit.

· Il est indispensable de garder le **ticket** ou facture d'achat et de communiquer le **Numéro de Control Qualité** pour une quelconque demande ou réclamation.

PT · Fabricado U.E. por FORES DISEÑO S.L. C.I.F: B-12313003 - Ctra.Nac.232; 11,1 km C.P. 12320 - Sant Jordi (Castellón) ESPANHA - que garante este produto por um período de **2 anos** a partir da data de compra; contra defeitos de fabricação.

· Se você encontrar qualquer dificuldade na montagem ou se houver qualquer defeito no armário, você pode contactar-nos pelos seguintes meios: **(+34) 964 46 52 22** ou por e-mail: **postventa@fores.es** onde será recebido de bom grado para atenderder-mos todas as suas dúvidas. HORÁRIOS: Segunda a sexta-feira das 9h às 14h e 15h às 18h.

· Esta garantia não cobre defeitos causados pela montagem incorreta, uso indevido ou mau trato do produto.

· É essencial manter o **recibo** de compra e facilitar o **Nº Controle de Qualidade** para quaisquer dúvidas ou reclamações.

IT · Prodotto in Spagna da: FORES DISEÑO S.L. CIF B-12313003-ctra Nac 232 km 11.1 C.P.12320-Sant Jordi, (Castellón) SPAIN. Garantito **2 Anni** dalla data di acquisto contro ogni difetto di produzione.

· In caso di difficoltà nel montaggio o di mancanza di componenti potete chiamare il **(+34) 964 46 52 22** o inviare email a: **postventa@fores.es**

· Il servizio è attivo dal Lunedì al Venerdì ore 9:00-14:00 / 15:00-18:00 Saremo lieti di aiutarvi.

· La garanzia non copre difetti o danni dovuti a montaggio scorretto o ad uso improprio del prodotto.

· La garanzia è valida solo in presenza dello **sccontrino di acquisto** e sarà più tempestiva se conservate il **nº di controllo qualità** presente nella confezione.

DE · Hergestellt in Spanien von FORES DISEÑO S.L. CIF B-12313003-ctra Nac 232 km 11.1 CP12320-Sant Jordi (Castellón) SPANIEN - Garantie von **2 Jahren** ab kaufdatum gegen jede störung der produktion.

· Wenn Sie irgendwelche schwierigkeiten bei der montage zu finden oder es irgendeinen defekt in dem schrank, können sie uns unter **(+34) 964 46 52 22** oder per email an: **postventa@fores.es**, wo wir gerne besuchen, um alle Ihre Fragen. ÖFFNUNGSZEITEN: Montag bis Freitag von 9h bis 14h und 15h bis 18h.

· Diese Garantie gilt nicht für Mängel, die durch unsachgemäße Installation, unsachgemäße Behandlung und Verwendung des Geräts verursacht werden.

· Unentbehrlich, um den **Kauf Ticket** behalten und erleichtern die Anzahl der **Qualitätskontrollzahl** für alle zu konsultieren oder Anspruch.

HR · Proizvedeno u Španjolskoj od strane FORES DISEÑO S.L. cif B-12313003-CTRA Nac 232 km 11,1 CP12320-Sant Jordi, (Castellón) Španjolska - jamstvo **2 godine** od datuma kupnje protiv krivnjom proizvodnje.

· Ako poteškoća kada se utvrdi Skupština ili greška u proizvodu možete nas kontaktirati na **(+34) 964 46 52 22** ili putem e-maila: **postventa@fores.es** gdje ćemo biti drago da vam pomogne. RASPORED: ponedjeljak do petka 9-14h / 15-18h.

· Jamstvo ne pokriva kvarove proizvodnji pogrešne montaže ili zlouporabe namještaja

· Neophodan zadržati kupnju **ulaznica** i olakšati **Nº kontrole kvalitete** za bilo konzultirati ili zahtjev.

TR · İspanya'da üretilen ile FORES DISEÑO S.L. CIF B-12313003-ctra Nac 232 km 11,1 CP12320-Sant Jordi, (Castellón) İSPANYA - satın alma tarihinden itibaren **2 yıl** garantisi üretimin herhangi bir arıza karşısında.

· Montaj veya üründe arıza bulunan bir zorluk zaman **(34) 964 46 52 22** veya e-posta yoluyla bizimle irtibata geçebilirsiniz ise: **postventa@fores.es** neredede olacak size yardımcı olmaktan mutluluk. PROGRAM: Pazartesi Cuma 9-14h / 15-18h kadar.

· Garanti mobilya yanlış montaj veya kötüye tarafından üretilen hataları kapsamaz.

· Bu satın alma **makbuzu** tutmak esastır ve herhangi bir soruşturma veya şikayetler için **Nº kalite kontrol**.

Nº de Control de Calidad:**Nº of Quality Control:****Nº de Contrôle Qualité:****Nº de Controle de Qualidade:****Nº di Controllo qualità:****Qualitätskontrollzahl:****Nº kontrole kvalitete:****Nº Kalite kontrol:****00000.16**



ZAPATERO 3 PUERTAS - SHOE'S CABINET 3 DOORS -
ARMOIRE À CHAUSSURES 3 PORTES - SAPATEIRA 3 PORTAS -
SCARPIERA 3 ANTE - SCHUHSCHRANK 3 FÄCHER -
ORMARIĆ ZA CIPELE 3 VRATA - AYAKKABI DOLABI 3 KAPILAR

